

# BROADCAST TRANSMITTING EQUIPMENT

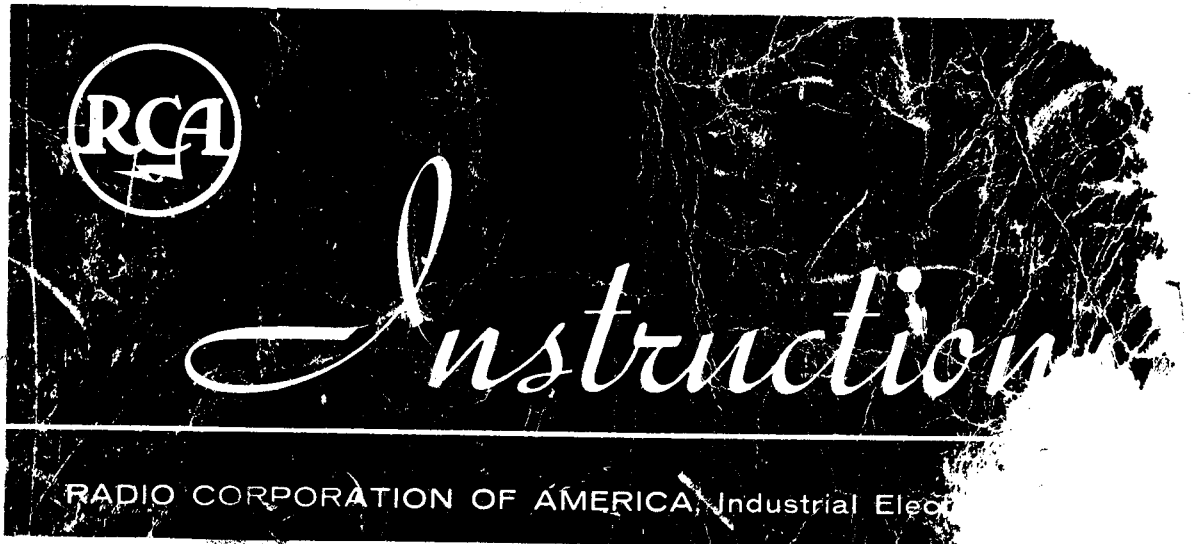

**BTA-500MX and BTA-1MX**

**AM Broadcast Transmitting Equipment**

## TABLE OF CONTENTS

	Page
<b>TECHNICAL SUMMARY</b> -----	6
Electrical Specifications -----	6
Mechanical Specifications -----	6
Tube Complement -----	6
<b>EQUIPMENT LIST</b> -----	7
<b>RECOMMENDED TEST EQUIPMENT</b> -----	7
<b>DESCRIPTION</b> -----	8
General -----	8
Construction -----	8
Component Identification -----	8
Circuits -----	9
Transmitter -----	9
Power-Determining Parts -----	10
Power-Change Circuit -----	11
60 to 50-Cycle Circuit -----	11
<b>INSTALLATION</b> -----	12
Layout -----	12
Transmission Line Layout -----	13
Atmospheric Static Accumulations -----	14
Electrical Storms -----	14
Unpacking -----	14
Items Removed for Shipment -----	15
Installing Power-Determining Parts -----	16
Installing Power-Change Kit -----	17
Installing Accessory Items -----	18
Completing Installation -----	19
<b>ADJUSTMENTS AND TUNING</b> -----	19
Adjustments -----	19
Transformer Taps -----	20
Control Circuit Check -----	20
Arc-Gap Adjustment -----	22
Tuning -----	22
Component Adjustments -----	22
Transmitter Tuning -----	26
Reduced-Power Operation -----	30
Adjusting Antenna Arc-Gaps -----	30
<b>METER READINGS</b> -----	31
<b>OPERATION</b> -----	33
Routine Operation -----	33
Overloads and Interruptions -----	33
Reduced-Power Operation -----	33
Fuses -----	33
<b>MAINTENANCE</b> -----	34
General -----	34
Cleaning -----	35
Air Filter -----	35

## TABLE OF CONTENTS (Continued)

	Page
Circuit Breakers and Relays -----	36
Tubes -----	36
Antenna Current Readings -----	36
Tube Socket Voltages -----	37
<b>PARTS LIST</b> -----	42
Crystal Oscillator Unit -----	43
BTA-500MX/1MX Basic Transmitter -----	43
BTA-500MX, Frequency-Determining Parts -----	46
BTA-1MX, Frequency-Determining Parts -----	47
BTA-500MX, Power-Determining Parts -----	49
BTA-1MX, Power-Determining Parts -----	50
Power-Change Kit; 1000/500/250 Watts, 500/250 Watts -----	50
60 to 50-Cycle Conversion Kit -----	50
Recommended Station Spares (BTA-500MX/1MX) -----	51
Insulator Data -----	52

## LIST OF ILLUSTRATIONS

Figure		Page
1	RCA Type BTA-500MX or BTA-1MX A-M Broadcast Transmitter -----	5
2	Connection Details for Power-Change Resistors (MI-28099) -----	18
3	Tuning Chart, Jumper Connections on PA Tank Coil 1L6 (8943600 sub 0) --	24
4	Typical Tower Lighting Circuit (8842553 sub 1) -----	36
5	Transmitter, Front View -----	38
6	Transmitter, Rear View, Part I -----	39
7	Transmitter, Rear View, Part II -----	40
8	Oscillator, Above Chassis View -----	41
9	Oscillator, Below Chassis View -----	41
10	Insulator Details (445796 sub 3) -----	53
11	Overall Schematic Diagram, BTA-500MX and BTA-1MX (318833 sub 5) ----	55
12	Outline, BTA-500MX or BTA-1MX Transmitter (8700160 sub 0) -----	57
13	Connection Diagram, Oscillator (429907 sub 7) -----	58
14	Connection Diagram, Transmitter Front (318834 sub 2) -----	59
15	Connection Diagram, Transmitter Rear (318834 sub 2) -----	61

## LIST OF TABLES

Table		Page
1	Component Symbol Designations -----	9
2	External Connections to BTA-500MX or BTA-1MX -----	13
3	Installing Power-Determining Parts -----	16
4	Transformer Primary Taps -----	20
5	Tube Socket Filament Voltages -----	21
6	Oscillator Coil Settings -----	22
7	Buffer Tank Settings -----	23
8	BTA-500MX Frequency-Determining Parts -----	25
9	BTA-1MX Frequency-Determining Parts -----	25
10	Step-By-Step Tuning Procedure, BTA-500MX and BTA-1MX -----	26
11	Typical Panel Meter Readings, BTA-500MX -----	31
12	Typical Panel Meter Readings, BTA-1MX -----	32
13	Recommended Overall Maintenance Schedule -----	34
14	Typical Tube Socket Voltages, BTA-500MX and BTA-1MX -----	37

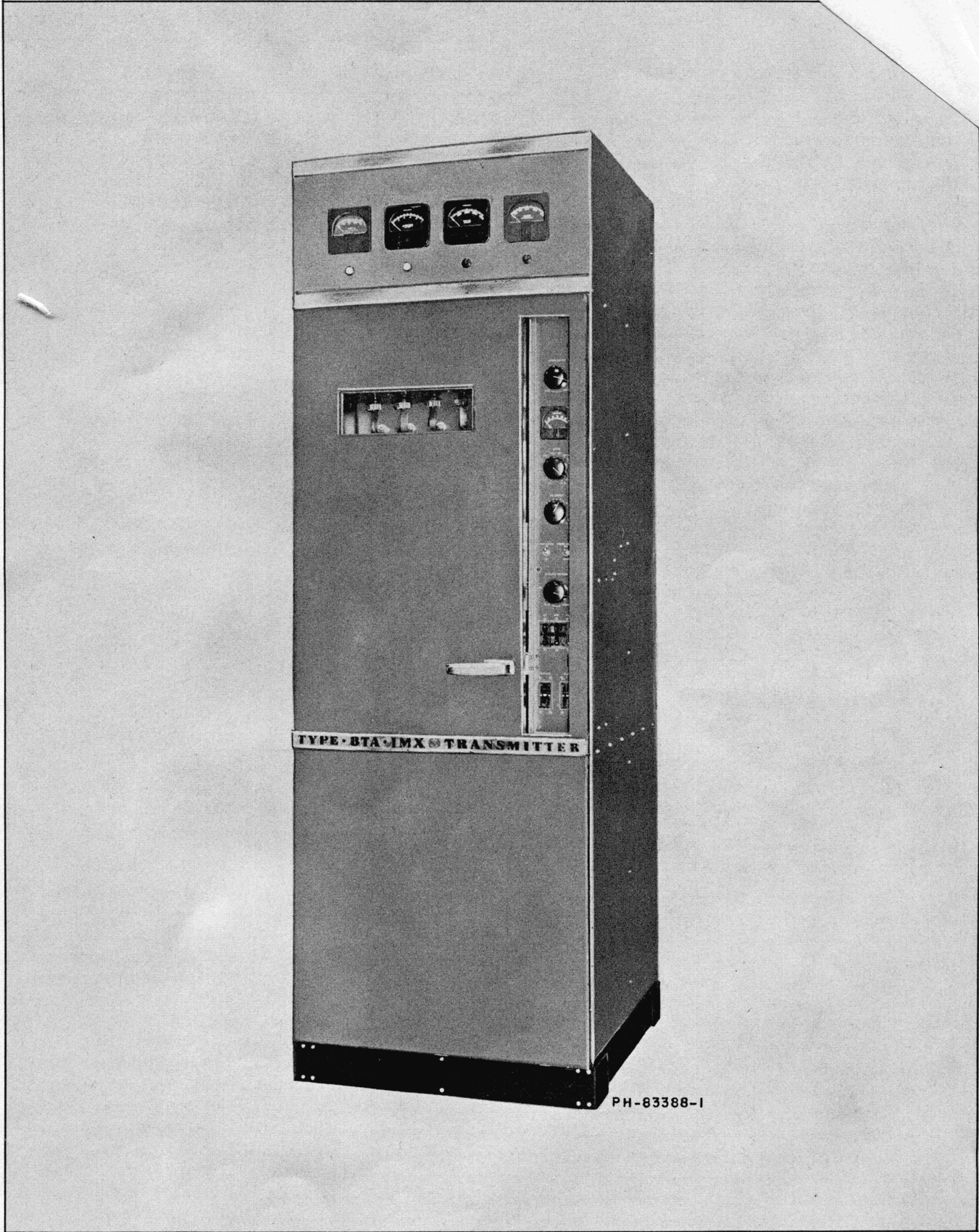

PH-83388-1

Figure 1. RCA Type BTA-500MX or BTA-1MX A-M Broadcast Transmitter



## TECHNICAL SUMMARY

### ELECTRICAL SPECIFICATIONS

	BTA-500MX	BTA-1MX
Type of Emission -----	A3 (telephone)	A3 (telephone)
Rated Power Output -----	500 watts	1,000 watts
Power Output Capability -----	550 watts	1,100 watts
Output Impedance -----	20 to 250 ohms	20 to 250 ohms
Type of Output -----	Single-ended	Single-ended
Frequency Range -----	535 to 1620 kc	535 to 1620 kc
Frequency Stability -----	±5 cycles	±5 cycles
A-F Input Level (100% mod.) -----	+10 ±2 dbm	+10 ±2 dbm
A-F Input Impedance -----	150/600 ohms	150/600 ohms
A-F Response: -----		
50 to 7,500 cycles -----	±1.0 db	±1.0 db
30 to 10,000 cycles -----	±1.5 db	±1.5 db
A-F Distortion (95% mod.), -----		
50 to 10,000 cps -----	2% max.	2% max.
Type of Modulation -----	High level, class B	High level, class B
Carrier Shift, 0 to 100% Modulation -----	Less than 5%	Less than 5%
Noise, Unweighted, Below 100% Modulation -----	60 db	60 db
R-F Voltage for Frequency and -----		
Modulation Monitoring -----	10 v. rms, 75 ohms	10 v. rms, 75 ohms
Main Power Supply -----	208/230 volts, 1 phase, *50 or 60 cycles	208/230 volts, 1 phase, *50 or 60 cycles
Power Consumption, Approx.: -----		
0% Modulation -----	2,050 watts	3,200 watts
30% Modulation -----	2,200 watts	3,500 watts
100% Modulation -----	2,580 watts	4,250 watts
Power Factor -----	90	90
Permissible Combined Line Voltage -----		
Variation and Regulation -----	±5%	±5%
Auxiliary Power Supply (Crystal Heater, -----		
Lights) -----	117 volts, 1 phase, 50/60 cycles	117 volts, 1 phase, 50/60 cycles
Crystal Heater Power Consumption -----	30 watts	30 watts
Ambient Operating Temperature, Max. -----	+45°C (+113°F)	+45°C (+113°F)
Altitude Range -----	0 to 10,000 feet	0 to 10,000 feet

### MECHANICAL SPECIFICATIONS

Height -----	84 inches
Width -----	27 inches
Depth -----	32 9/16 inches
Weight, BTA-1MX -----	1,500 pounds, approx.
Weight, BTA-500MX -----	1,300 pounds, approx.

### TUBE COMPLEMENT

Crystal Oscillator -----	1 RCA Type 807
Buffer -----	2 RCA Type 807
Power Amplifier -----	**2 RCA Type 833A
First Audio -----	2 RCA Type 807
Second Audio -----	2 RCA Type 807
Modulator -----	2 RCA Type 833A
Low-Voltage Rectifier -----	2 RCA Type 866A
High-Voltage Rectifier -----	2 RCA Type 8008

\*Transmitter requires conversion kit for 50-cycle operation.

\*\*BTA-500MX uses one 833A.

## EQUIPMENT LIST

The Types BTA-500MX and BTA-1MX Broadcast Transmitting Equipments are identified by the following RCA reference numbers:

BTA-500MX	-	ES-28949-A
BTA-1MX	-	ES-28939-B

Items comprising and associated with each equipment are as follows:

QUANTITY	DESCRIPTION	RCA REFERENCE	
		BTA-500MX	BTA-1MX
1	Basic Transmitter -----	MI-27090-A	MI-27090-A
1	Set of Frequency-Determining Parts -----	MI-27093	MI-28096-A
1	Set of Power-Determining Parts -----	MI-27092-A	MI-27091-A
1	Nameplate -----	MI-28180-1	MI-28180-1
1	Touch-Up Finish Kit -----	MI-7499-A	MI-7499-A
*	TMV-129B Crystal Unit, including crystal, for customer's assigned frequency -----	MI-7467	MI-7467
*	Type BPA-11A Antenna Tuning Equipment --	ES-28906-A	ES-28906-A
*	R-F Output Meter, for customer's frequency and antenna -----	MI-7157-F-	MI-7157-F-
*	Conversion Kit, 60 to 50 Cycles -----	MI-28098	MI-28098
*	Set of Operating Tubes -----	MI-27094	MI-28097
*	Set of Spare Tubes, FCC Requirements ---	MI-28094	MI-28094
*	Power Change Kit 1000/500/250 KW, 500/250 KW -----	MI-28099	MI-28099
2	Instruction Book -----	IB-30239	IB-30239
*	Antenna Phasing Equipment -----	ES-28927	ES-28927
*	Remote Pick-Up Unit, for use with Remote Antenna Ammeter -----	MI-28027-A	MI-28027-A
*	Remote Antenna Ammeter for customer's antenna -----	MI-28037	MI-28037

\*Supplied if and as specified on sales order.

## RECOMMENDED TEST EQUIPMENT

The following items, or equivalents, are necessary for adjustment, tune-up, and maintenance of the BTA-500MX and BTA-1MX transmitters:

<u>RCA REFERENCE</u>	<u>ITEM</u>
WA-28A	Audio Oscillator
WM-71A	Distortion and Noise Meter
WV-97A	VoltOhmyst
WO-88A	Oscilloscope

## DESCRIPTION

### GENERAL

The RCA Types BTA-500MX and BTA-1MX transmitters, illustrated in Figure 1, are designed for high-fidelity a-m broadcasting on any frequency from 535 kc to 1,620 kc. The BTA-500MX transmitter has a nominal rated power output of 500 watts, while the BTA-1MX equipment provides 1,000 watts nominal output. Maximum power outputs, to compensate for losses in the transmission line and antenna tuning equipment, are 550 watts and 1,100 watts, for the BTA-500MX and BTA-1MX units, respectively.

The transmitters are complete, self-contained units and employ air-cooled tubes throughout. Close regulation of the output frequency is provided by a crystal mounted in a thermostatically-controlled, heated enclosure. An input power source of 208/230 volts, 60 cycles, 1 phase, is required for transmitter operation; the crystal heaters utilize 117 volts, 50/60 cycles, 1-phase power.

Items associated with the transmitters include the BPA-11A antenna tuning equipment, an r-f output meter, a remote antenna ammeter, antenna phasing equipment, and speech input and monitoring equipment. An optional kit enables the transmitters to be operated from a 50-cycle power input.

Where reduced output power is required by day-night broadcasting conditions, the optional power change kit, MI-28099, provides means for the required reduction. This kit enables the BTA-500MX power to be decreased from 500 to 250 watts, and the BTA-1MX output to be cut from 1,000 to either 500 watts or 250 watts.

### CONSTRUCTION

The transmitter is contained in a metal cabinet which rests on metal wiring ducts, front and rear. Removable plates on these ducts provide for easy access to interconnecting wiring.

Vertical panel construction is utilized to provide maximum accessibility for maintenance or servicing. All operating controls are mounted on a recessed vertical panel, on the right-hand side of the cabinet. Both doors are interlocked so as to open high-voltage supply lines and automatically ground the high-voltage circuits. An air interlock switch protects the equipment in the event of reduction in or loss of air pressure.

### COMPONENT IDENTIFICATION

Each component in the transmitter bears a letter which indicates the class or type of component, while the final number identifies the individual items. Table 1 lists the types of components by their symbol or alphabetical classification.

TABLE 1. COMPONENT SYMBOL DESIGNATIONS

SYMBOL DESIGNATION	ITEM
B	Blowers, motors, phase shifters
C	Capacitors
CR	Crystal or metallic rectifiers
F	Fuses
I	Indicator lamps
J	Connector jacks
K	Relays or contactors
L	Inductors
M	Meters
P	Connector plugs
R	Resistors
S	Switches or interlocks
T	Transformers
TB	Terminal boards
V	Tubes
XC	Sockets for capacitors
XI	Sockets for lamps
XV	Sockets for tubes
Y	Crystals (oscillating)
Z	Impedance networks

## CIRCUITS

### Transmitter

The transmitter r-f circuits consist of a crystal oscillator driving a two-tube buffer-driver stage which in turn drives a plate-modulated PA stage. In the BTA-500MX, one PA tube is used, while the BTA-1MX utilizes two PA tubes in parallel. Figure 11 is the overall schematic diagram, on which the added components for the BTA-1MX are indicated with a single asterisk. The double asterisk indicates components used only in the BTA-500MX. No air-dielectric capacitors are used where there is likelihood of arc-over due to accumulation of foreign matter.

Referring to the schematic diagram, crystal oscillator 1Y2 uses a type 807 tube and has only two adjustments. Variable capacitor C1 adjusts the crystal frequency within narrow limits and is the only variable adjustment in this stage. The other adjustment is on tapped plate inductor L1 which is made at the time of installation or when the operating frequency is changed. Pilot light 1I1 shows when the crystal heater is energized. A spare crystal socket, 1XY1, enables a heated spare crystal to be substituted instantly for the operating crystal. Crystal heater circuits are protected by fuses 1F1 and 1F2.

Two type 807 tubes, 1V1 and 1V2, are used in parallel in the buffer-amplifier stage, with tapped plate coil 1L3 tuned by one or two fixed capacitors, 1C5 or 1C6. This adjustment is made during the initial tune-up or when the transmitter frequency is changed. Capacitor 1C7 is in series with capacitor 1C5 or 1C6 and ground and is shunted by variable resistor 1R9, forming an adjustable divider to supply an r-f signal through jack 1J1 for the station frequency monitor. Screen grid modulation, applied to this stage through a tap on 1T4, increases the PA drive on modulation peaks and reduces distortion.

The BTA-500MX has a single type 833A tube, 1V3, in the PA stage while the BTA-1MX uses two parallel-connected 833A tubes, 1V3 and 1V4. This stage is operated class "C" and is plate modulated. Capacitors 1C16 and 1C17 form a voltage step-down divider for neutralizing transformer 1T1, the output of which is coupled to the tube grids through neutralizing capacitor 1C20. Plate inductor 1L6 is tuned by a silver-plated copper slug and is the only tuning control in the transmitter.

Inductors 1L6 and 1L7, tuned by combinations of capacitors 1C21 through 1C26, make up a double pi-network, which presents the same impedance to both sidebands and results in minimum distortion. In addition, this network matches the low-antenna or transmission-line impedance to the high-plate impedance and reduces harmonic radiation. Power output is controlled by resistor 1R71, which varies the plate voltage applied to the PA stage.

R-f voltage at 10 volts, 75 ohms, for modulation monitoring, is supplied through transformer 1T2 and jack 1J2. Secondary taps on transformer 1T2 provide for output voltage adjustment.

The audio system consists of three cascaded push-pull stages. Input coupling to the first stage is provided by transformer 1T3, the primary of which may be connected in parallel for a 150-ohm input or in series for a 600-ohm input. The 20-db feedback voltage from feedback ladders 1Z1 and 1Z2 is applied to the first audio stage through transformer 1T3. The two type 807 tubes, 1V5 and 1V6, operate as class "A" amplifiers.

The second audio stage consists of two 807 tubes, 1V7 and 1V8, operating as cathode followers to drive the type 833A modulator output tubes, 1V9 and 1V10. Bias voltage on these tubes is adjustable by means of variable resistors 1R54 and 1R55. As these resistors adjust the bias, tubes 1V7 and 1V8 then draw more or less current, changing the voltage drop across cathode resistors 1R32 and 1R33 and the bias on modulator tubes 1V9 and 1V10.

Three d-c power supplies furnish the required plate and screen grid voltages. A pair of type 8008 tubes, 1V13 and 1V14, supply the high voltage for the PA and modulator tubes; two type 866/866-A tubes supply the required voltages for the remainder of the transmitter. A selenium rectifier furnishes the audio bias voltages. Filament voltages on all tubes can be adjusted by variable resistor 1R50, controlled from the front panel. Voltmeter 1M1 indicates the filament transformer input voltage.

The power control circuits utilize a time-delay relay, 1K1, to prevent application of plate power until thirty seconds after the filament power has been applied. In addition, the plate voltage will be interrupted if shorts occur in the filament circuit. The transmitter will return to the air immediately following a power line interruption up to two seconds' duration. If the power interruption exceeds two seconds, the transmitter will return to the air thirty seconds after power is restored.

#### Power-Determining Parts

Since the BTA-500MX and BTA-1MX transmitters utilize identical circuitry up to the r-f output stage, the required output or power-determining parts are supplied as a separate "MI" or group of components. For 500 watts output power (BTA-500MX), MI-27092-A is furnished; for 1,000 watts output (BTA-1MX), MI-27091-A. Major difference between the two groups of components is in the size and value required for 1,000 watts output. Items involved are:



<u>COMPONENT</u>	<u>SYMBOL</u>
PA neutralizing capacitor	1C20
Modulator output coupling capacitor	1C51
High-voltage filter reactor	1L13
Modulation reactor	1L14
PA plate current meter	1M3
<del>PA grid resistor</del>	<del>1R10</del>
AF amplifier screen resistor (BTA-500MX only)	1R19
<del>PA overload resistor</del>	<del>1R70</del>
Output control rheostat	1R71
AF amplifier cathode resistor (BTA-500MX only)	1R72
Modulation transformer	1T4
High-voltage plate transformer	1T11
<del>PA filament bypass capacitors (BTA-1MX only)</del>	<del>1C13, 1C14</del>
Equalizer (BTA-500MX only)	1Z3

*PA Grid Resistor*  
*1R10*

Power-Change Circuit

The optional power-change, or cut-back circuit, is utilized where reduced output power is required for night operation. This circuit incorporates the MI-28099 kit, and enables the BTA-500MX output to be reduced to 250 watts or the BTA-1MX to 500 watts or 250 watts, as required. In each case only one switch need be operated after the kit is installed.

Connections for the power-change circuit are shown at the extreme right on the schematic diagram, Figure 11. The circuit is energized when panel switch 1S11 is placed in the low-power position. This energizes relay 2K1, which connects selected combinations of resistors 2R1 to 2R8 in the high-voltage plate circuit. Resultant decrease in plate voltage is reflected in reduced r-f output power. Specific connections for a particular power reduction are supplied under INSTALLATION.

60 to 50-Cycle Circuit

Where a 50-cycle power input is used, the only item affected is blower motor 1B1. All other components are suitable for 50 or 60-cycle operation. A 50-cycle motor is available as MI-28098.

## INSTALLATION

### LAYOUT

Basic step in installation of the BTA-500MX and BTA-1MX transmitters is to decide upon the equipment layout and make provisions for the necessary external connections. After the necessary space is available, the equipment can be unpacked, assembled, and connected as specified. Outline dimensions for the transmitter and the optional antenna phasing equipment are shown in Figure 12.

Inasmuch as some of the optional and associated items include their own instruction book, the installation procedure for such units will not be repeated. Instead, reference should be made to the instruction books (IB's) accompanying such equipment. These books are:

BPA-11A Antenna Tuning Unit	-----	IB-30223
Remote Pick-Up Unit	-----	IB-30209
Coaxial Transmission Lines	-----	IB-36164

Factors to be considered in layout are incoming power lines, accessibility of a good station ground, and route for the transmission line to the antenna. The room in which the transmitter is to be installed should be well-ventilated and have an abundant supply of clean, dry air. The maximum ambient temperature is listed under TECHNICAL SUMMARY.

Separate disconnect switches and power leads must be supplied for the 230-volt and 117-volt incoming power lines. Note that the crystal ovens require a separate 117-volt line so that the ovens may be energized 24 hours a day without interruption.

Disconnect switches and wiring must be provided for such items as the transmitter room exhaust fan, if any, and any monitoring racks. The tower lighting circuit should also be planned, although no material is provided for this item.

Wiring to and from the transmitter should be carried in conduit or a trench terminating below the unit. The base plan of the outline drawing, Figure 12, indicates where this wiring should enter the unit. The ground connection indicated in Figure 12 must be connected to the station ground, using copper strap about 1 inch wide. Table 2 lists the external connections to be made.

It is not intended that these instructions shall supersede any applicable local codes. Where the instructions in this book conflict with any local electrical, construction, or building code, the provisions of the applicable local code should be followed.

TABLE 2. EXTERNAL CONNECTIONS TO BTA-500MX OR BTA-1MX

POINT OF CONNECTION	EXTERNAL CIRCUIT
1A 2A	117 volts, 50/60 cycles for crystal heater
3A 4A	117 volts, 50/60 cycles for cabinet lamps
5A 6A	208/230 volts, 60 cycles, power input
7A 8A	Contacts to close an external circuit when plate voltage is removed from the transmitter.
9A 10A	External plate voltage interlock connections
11A 12A	Remote antenna ammeter
13A 14A	Spare
15A 16A	Audio input, 150 or 600 ohms impedance
25A	Antenna transmission line terminal
26A	Ground terminal for antenna transmission line
1J1	R-f to frequency monitor
1J2	R-f to modulation monitor

### TRANSMISSION LINE LAYOUT

The r-f output from the transmitter terminates at the insulated fitting, as shown in Figure 12. Beyond this point no lines or fittings are supplied with the transmitter, but must be ordered separately.

A coaxial or open-type wire transmission line with a resistive impedance of either 51.5 ohms, 72 ohms, or 230 ohms may be used. The coupling network capacitors supplied serve to match the transmitter output to a specific transmission line impedance at any operating frequency.

Where an underground transmission line is to be used, coaxial lines and fittings must be employed. Layout information, dimensions, and installation data for the required 1 5/8" or 3 1/8" coaxial transmission lines are supplied in the transmission line instruction book IB-36164. If coaxial transmission line is used, the installation of items such as dehydrating or gassing units, if required, should not be overlooked. Data for installation of these items is also supplied in the transmission line instruction book, IB-36164.

The RCA Type BPA-11A Antenna Tuning Unit is recommended for matching the antenna to the BTA-500MX or BTA-1MX transmitter. If desired, the unit can also be furnished to supply an a-f voltage for program monitoring, and a rectified carrier current for remote antenna current indication.

An antenna tuning house is also desirable, especially when multi-element arrays are used, since it offers weather protection and facilities for test and measuring units, tower lighting equipment, and intercommunication components.

Before completing the layout from the transmitter to the transmission line and antenna, station engineering personnel should check the antenna system for protection against atmospheric static accumulations and electrical storms. If this is not done, the transmitter may be damaged. Refer to the next two headings for a discussion of the details involved.

### ATMOSPHERIC STATIC ACCUMULATIONS

In certain localities, atmospheric conditions build up high static potentials on the antenna towers, making it imperative to provide a drain path to ground for these accumulations. If no direct path is provided, the charge will build up potential until flashover occurs, either across the tower base arc-gap or across one of the capacitors in the antenna coupling system.

Where tower lighting chokes are used and one side of the a-c supply line is grounded, the lighting choke will act as a satisfactory discharge path. When neither side of the a-c line is grounded, or when a toroidal tower lighting transformer is utilized a drain path must be provided. Such a path, however, may already exist in the transmitter output circuit or antenna coupling unit. Existence of such a path may be checked after installation and before any circuits are energized, by connecting an ohmmeter between the tower and ground. Any resistance up to approximately 250,000 ohms will provide a satisfactory return circuit. When no discharge path is indicated, one may be supplied by the installation of an r-f choke or a 100,000 to 200,000-ohm Globar resistor. Connect either the choke or the resistor from the antenna feed line to ground. The line terminating unit will generally serve to house the component used.

### ELECTRICAL STORMS

In areas subject to lightning storms, a direct electrical path from the tower to ground is required to avoid capacitor and antenna current meter burnout if lightning strikes the tower. This requirement can generally be met by installing arc-gaps across the base insulators. If these gaps are properly spaced, at the instant of discharge the gaps will present a low impedance path to ground and thus carry directly to ground any current caused by the lightning striking the tower. Although there is a second path to ground through the tuning equipment or transmitter output, the higher impedance of this second path usually prevents excessive discharge under normal conditions. In instances where the tuning house is located under the tower or directly adjacent to it, the ratio of these two impedances may not be sufficiently high to prevent appreciable discharge current through the tuning equipment to ground with consequent destruction of the coupling equipment. To increase this ratio, a one- or two-turn loop should be installed in the antenna lead from the tower to the tuning house. No such loop is required where the tuning house is more than several feet from the tower. In the latter instance, the longer lead provides the necessary higher impedance.

### UNPACKING

When the equipment is delivered the carrier will present a shipping receipt for signature. This receipt should not be signed without first inspecting each container for visible damage and counting the number of containers for comparison with the amount shown on the shipping papers. If visible damage is apparent or a shortage exists, a notation to that effect should

be made on the shipping papers before signing. Then file the proper claim with the carrier.

After unpacking the equipment, inspect all items for concealed damage. If concealed damage is apparent, notify the carrier immediately in writing and insist upon an inspection and report. File a claim for the damage. All shipping papers, letters, and invoices should be saved until certain that the equipment was delivered in good condition or until any damage claim has been adjusted satisfactorily. Note that most carriers place a time limit on their responsibility for shortages or damage, hence unpacking should not be unduly delayed.

An understanding of the overall shipping system will be of assistance in unpacking the equipment and locating items. Each RCA equipment is accompanied by a packing list which lists the complete contents of the shipment by "master item" or "MI" numbers. This shipping voucher is usually packed in one of the smaller cardboard cartons, appropriately marked.

Where more than one item is listed on an MI, a sub-division or "item" number is listed after the MI number. Thus, a component might carry the designation, "MI-99999-2." This indicates that the part is "item 2" on the MI-99999 list. These MI sheets are essentially packing lists, and where there are two or more boxes to a major unit, the box containing the MI sheet is identified by stenciling. Thus it is possible to identify the contents of each box and plan the overall uncrating systematically. All items listed on the MI sheets should be located before crates or boxes are destroyed, to avoid loss of small items overlooked during unpacking.

The MI sheets, as previously noted, are of value only in locating items for assembly. The MI sheets should not be used for installation sequence nor for installation details. Refer to the appropriate drawings and the following notes for this information.

The equipment may now be unpacked. Tubes and crystals should not be unpacked until required. In addition, the frequency-determining parts, MI-27093 or MI-28096-A, should be left in their carton until installation is specified.

#### ITEMS REMOVED FOR SHIPMENT

Various components have been removed from their operating position and packed separately for shipment. All such parts are individually tagged with an MI and item number. Do not remove any identification tags until all components have been installed. In most cases the symbol designation of each electrical component is stenciled adjacent to the item's normal mounting location. Hardware required for reassembly is shipped in place or the required hardware items will be specified as needed. The following notes apply to both the BTA-500MX and BTA-1MX transmitters, since both utilize the basic transmitter, MI-27090-A.

Before making any connections or installing any components, operate all switches and breakers to the OFF position. This will prevent possible injury or equipment damage if the incoming power switch is closed accidentally.

Referring to Figure 5, install blower 1B1, item 3 of MI-27090-A, at the lower front of the cabinet. Use mounting hardware item 5 of MI-27090-A. Connect the blower as shown in Figure 14. If the 60 to 50-cycle kit, MI-28098, is to be installed, replace the 60-cycle motor with the 50-cycle motor.

Install capacitor 1C15, item 4 of MI-27090-A, in the upper rear, as shown in Figure 6. Use mounting hardware in place. Figure 15 is the connection diagram for the rear of the transmitter.

Place a cap on the ends of the compartment lamps and install one lamp in the upper front and rear of the cabinet. Use item 2 of MI-27090-A.

Don't install the oscillator unit, item 11 of MI-27090-A, at this time; installation will be covered under "Tuning."



## INSTALLING POWER-DETERMINING PARTS

To install the power-determining parts, refer to Table 3, which lists the components and the associated photographs and connection diagrams.

TABLE 3. INSTALLING POWER-DETERMINING PARTS

BTA-500MX (MI-27092-A)	BTA-1MX (MI-27091-A)	COMPONENT	WHERE INSTALLED	REFER TO:	
				PHOTO- GRAPH	DIAGRAM
Item 1	Item 1	capacitor 1C20	upper rear	Fig. 6	Fig. 15
2	2	capacitor 1C51	lower rear	6	15
3	3	reactor 1L13	lower rear	7	15
4	4	reactor 1L14	lower front	5	14
5	5	meter 1M3	front panel	5	14
6	6	resistor 1R10	rear center	7	15
7	7	resistor 1R70	front panel (on switch 1S6)	5	14
8	8	rheostat 1R71	front panel	5	14
10	10	transf. 1T4	lower rear	7	15
11	11	transf. 1T11	lower front	5	14
-	14	capacitor 1C13, 1C14	upper front (at 1V4)	-	11
-	15	conn. for 1V4	upper front	5	14
17	-	resistor 1R19	rear center	7	15
18	-	resistor 1R72	upper rear (near 1S7)	-	15
19	-	equalizer 1Z3	upper rear (to left of 1T3)	6	15

NOTE: Mounting hardware for items 13 and 16 is as follows:

13A, 13C for 1C20  
13B, 13D for 1C51  
16A to 16H for 1C13, 1C14

Use care when installing transformer 1T4. If not located properly, the transformer terminals will short-circuit on the metal screen of the air filter. Best procedure is to slide the transformer forward until it is stopped by the center partition. Then move the transformer back about 1/2 inch from the center partition.

Install the knob, MI-27090-A-7, on rheostat 1R71.

In the BTA-500MX transmitter replace resistors 1R19 and 1R72 (connected in the basic transmitter) with items 17 and 18. Mount item 19 beside transformer 1T3 and connect it in series with the input to 1T3.

PA tube connectors should be allowed to hang loosely until the tube is installed. Wiring for the power-determining parts is already in place.

After the preceding parts have been installed, fasten the item 12 trim strip in place, using hardware items 13E and 13F.

### INSTALLING POWER-CHANGE KIT

The optional power change kit, MI-28099, is to be mounted on the right-hand panel of the inside rear of the transmitter cabinet. The panel is provided with holes and printed symbols for mounting and locating the various components. Necessary hardware and connecting wire are supplied.

Mount item 1, capacitor 2C1, above and to the left of stenciled symbol number, 2C1, using the screws and lockwashers supplied in item 6.

Mount relay 2K1, item 2, above and to the left of the stenciled symbol number 2K1, using the materials supplied in item 7. From the outside, screw three 1/2" screws with lockwashers into the three threaded holes. Tighten the screws and thread the three insulators, item 7A, onto the three screws inside the cabinet. Mount the relay on the insulators using the remaining screws, the longer screw going through the thicker part of the relay base.

Next, mount the parts included in item 8 so as to make up four vertical rows of resistor clips. First mount the insulators, by screws and lockwashers supplied, using the sixteen holes in the panel above the relay and capacitor. Do not tighten the screws fully until the insulators are properly squared up. Assemble the other hardware by putting a lockwasher on each screw, then a locking plate, and then a mounting clip. Screw the assembly on the insulators so that eight resistor mountings are formed. Tighten the mounting screws. The power-change kit is now ready for wiring.

For wiring details, refer to the layout on Figure 15. Use the item 10 bus for connections, and the item 9C terminals for both ends of each bus connection.

Cut the jumper for relay 2K1 from item 11, the 600-volt, 26-strand wire. Solder terminals, using item 9A or 9B, on the ends of the wire. Use the same type wire and terminals to connect the relay coil to terminals 1 and 2 of terminal board TB3. This terminal board is located on the right-hand side of the transmitter panel near the bottom. Dress the leads neatly.

Use the wire supplied as item 12 for connecting resistors 2R1 and 2R8 to terminals 126A and 127A, after removing the jumper between these terminals. These cables carry high voltage and should be routed accordingly. Terminals 126A and 127A are on the left-hand side of the rear transmitter panel below 1R50. Use item 9C terminals on the ends of the wires. The wiring layout for these resistors, as shown in Figure 15, covers the connections only for a power reduction from 1,000 to 500 watts. For the proper method of connecting resistors 2R1 to 2R8, to cover the various power-change outputs, refer to Figure 2.

Using item 12 wire, make a jumper for resistor 2R8 of sufficient length to short-circuit the resistor; place item 9C terminals on each end, and items 9D screw, 9F flat washer, 9G lockwasher, and 9I nut on the free end for fastening to the resistor taps. Connect this jumper to short-circuit a portion of 2R8 as indicated in Figure 2.

Place the item 3 resistors, 2R1 to 2R6, in their clips. Use the item 4 resistor for 2R7 and the item 5 resistor for 2R8, and install them in their clips.

POWER CHANGE	RESISTOR CONNECTIONS	EFFECTIVE RESISTANCE 2 R 8	TOTAL NETWORK RESISTANCE (APPROX.)
1,000 TO 500 WATTS (BTA-1MX)		270 OHMS	1,920 OHMS
1,000 TO 250 WATTS (BTA-1MX)		405 OHMS	4,605 OHMS
500 TO 250 WATTS (BTA-500MX)		45 OHMS	3,795 OHMS

Figure 2. Connection Details for Power-Change Resistors (MI-28099)

#### INSTALLING ACCESSORY ITEMS

If the MI-7157-F r-f ammeter is to be installed for reading the transmitter r-f output, the meter should be mounted behind the ANTENNA CURRENT meter case on the front panel, using the brackets and hardware supplied. Connect the meter as shown in the schematic diagram, Figure 11.

To prevent excessive r-f voltages from developing across the meter movement, it is necessary that the dummy meter case be used to insulate the meter from the front panel. In addition, the meter plate, the thermocouple, and the meter should be connected together with a common bus, as shown in the following illustration. This bus should be connected between the "G" terminal of the meter, the transmitter side of the thermocouple, and the meter-mounting plate.

Care should be taken in routing the leads from the thermocouple to the meter. Leads must be kept at a safe distance from the transmitter chassis and dressed with equal spacing, as is normally done with open-wire transmission line.

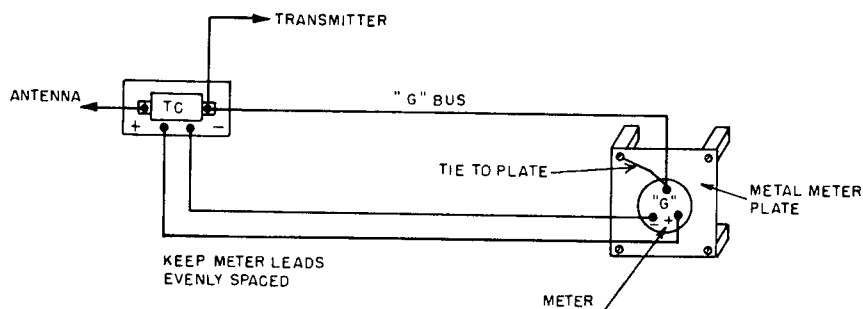

### PROPER METHOD FOR CONNECTING MI-7157-F AMMETER

When the BPA-11A Antenna Tuner and the MI-28037 Remote Antenna Ammeter are utilized, remove the dummy meter case, and mount the MI-28037 Remote Antenna Ammeter directly on the meter panel. Wire the meter as indicated in the upper right-hand corner of the schematic diagram, Figure 11. Terminals 11A and 12 should be connected to the Remote Pick-Up Unit.

### COMPLETING INSTALLATION

When all components except the frequency-determining parts have been installed, make the external connections required. Carefully check the wiring for accuracy. If a buzzer and battery are used for checking, temporarily short-circuit all meters in the transmitter, or disconnect one side of each meter, to prevent meter damage.

Check the high-voltage grounding switches, 1S9 and 1S10, for proper operation, using a battery and buzzer or the lowest scale on an ohmmeter.

Install the nameplate, item 11 of ES-28949-A, or item 12 of ES-28939-B on the front vertical panel, below tubes 1V10 and 1V3.

Set aside the tubes, oscillator unit, crystal, and frequency-determining parts for specific instructions under the next heading, **ADJUSTMENTS AND TUNING**.

## ADJUSTMENTS AND TUNING

### ADJUSTMENTS

Before applying any voltages to the transmitter, make sure the primary leads to plate transformers 1T6 and 1T11 are disconnected. Carefully tape and insulate these leads to prevent accidental contact or grounding.

## Transformer Taps

Check to make certain no transmitter tubes have been installed in their sockets, and that all circuit breakers and switches are in the OFF position, including the blower switch on the panel behind the front door.

Set FILAMENT VOLTAGE control 1R50 to the extreme clockwise position, then close FILAMENT circuit breaker 1S1. Read the incoming line voltage on FILAMENT VOLTAGE meter 1M1. Open the FILAMENT circuit breaker. Based on the voltage reading, adjust the primary taps, if necessary, in accordance with Table 4. This will insure proper operating voltages for maximum component life and design output.

TABLE 4. TRANSFORMER PRIMARY TAPS

TRANSFORMER	208-VOLT LINE			230-VOLT LINE		
	-5%	208 V.	+5%	-5%	230 V.	+5%
1T5	190	190	205	205	220	220
**1T6	208, -11	208, 0	208, +11	230, -11	230, 0	230, +11
1T7	190	190	205	205	220	220
1T8, 1T9	190	190	205	205	220	220
1T10	3-4	2-4	1-4	3-5	2-5	1-5
**1T11	208, -11	208, 0	208, +11	230, -11	230, 0	230, +11
*Using 1R50, adjust for these readings on 1M1	190	190	205	205	220	220

\*Adjust later, when specified.

\*\*Do not connect at this time, since primary leads must be disconnected during initial tuning.

Check the crystal, and spare, to be certain the frequency is correct, then install the crystals in their sockets. The crystal frequency should be the same as the assigned frequency.

## Control Circuit Check

Before any attempt is made to apply plate and bias voltages to the transmitter, the control and protective circuits should be checked to insure that all connections have been made properly. This will make certain of the designed equipment protection and prevent possible damage to components. The cause of any deviation from specified operation should be corrected immediately before proceeding with any subsequent operations.

Close the incoming power line switches which supply 115 volt, single-phase ac for the crystal heaters and cabinet lights. The CRYSTAL HEATER 1 and CRYSTAL HEATER 2 lights, 1I1 and 1I2, should glow and will be energized intermittently with operation of the crystal heater thermostats. The lumiline lamps at the front and rear of each cabinet should light when the CAB. LIGHTS switch, 1S12, is closed.



Make sure the two doors are closed, then close FILAMENT breaker 1S1, lighting POWER ON lamp 1I3. Rotate the FILAMENT VOLTAGE rheostat, 1R50, to the extreme counterclockwise position.

Approximately 30 seconds after breaker 1S1 is closed, time-delay relay 1K1 will operate, closing contacts in the plate control circuit. Plate power, however, cannot be applied since the air interlock is not closed in this circuit.

Open the front door and operate BLOWER breaker 1S15 to the ON position. Then close the door. As blower 1B1 reaches operating speed, air interlock switch 1S16 will close.

Close the following circuit breakers: LP, 1S5; PA, 1S6; and MOD., 1S8. This will complete the interlock circuit, and contactor 1K2 will close in the plate circuit.

Close PLATE breaker 1S2, lighting PLATE ON lamp 1I4. To check operation of the interlock circuit, open and close the L.P., PA, and MOD. circuit breakers, one by one. In each case, as the breaker is opened, PLATE ON lamp 1I4 should be extinguished and relay 1K2 should be de-energized.

To check operation of the door interlocks, the circuit breakers should be closed so that the PLATE ON lamp is glowing. Then, one by one, open and close the doors. Again, the PLATE ON lamp should go out and relay 1K2 should open.

When all circuits have been checked, operate all circuit breakers and the BLOWER switch to the OFF position.

Rotate the FILAMENT VOLTAGE control, 1R50, to the mid-position and close the FILAMENT breaker, 1S1. Using a voltmeter of known accuracy, measure the filament voltage at each tube socket. These voltage readings should be approximately as listed in Table 5 but will generally be slightly higher since tubes are not in the sockets.

TABLE 5. TUBE SOCKET FILAMENT VOLTAGES

TUBE SYMBOL	SOCKET VOLTAGE	POINT OF MEASUREMENT
*V1	6.3	pins 1-5
1V1, 1V2	6.3	pins 1-5
1V3	10	filament straps
1V4 (BTA-1MX only)	10	filament straps
1V5, 1V6	6.3	pins 1-5
1V7, 1V8	6.3	pins 1-5
1V9, 1V10	10	filament straps
1V11, 1V12	2.5	pins 1-4
1V13, 1V14	5	pins 2-3

\*Remove cover to obtain reading, but do not replace cover at this time.

Install all tubes in the transmitter but do not connect the plate caps on the type 866/866A tubes, 1V11 and 1V12, or the type 8008 tubes, 1V13 and 1V14. Make sure the plate caps on these tubes do not touch ground.

Apply filament power by closing the FILAMENT breaker. Allow the transmitter to operate in this condition for a minimum of 30 minutes. This procedure will expel all mercury globules from the filaments of the types 866/866A and 8008 rectifier tubes. This 30-minute "seasoning" procedure should be repeated whenever new tubes are installed. In the future, whenever the mercury-vapor rectifier tubes are removed from their sockets, they should be handled carefully and in an upright position. If this is not done, it will be necessary to repeat the 30-minute break-in procedure before plate voltage is applied.

While the rectifier filaments are being seasoned, adjust FILAMENT VOLTAGE control 1R50 for the exact reading specified in Table 4. After seasoning, operate all circuit breakers and switches to the OFF position.

#### Arc-Gap Adjustment

Adjust the arc-gap on the filter reactor, 1L13, for 1/16 inch spacing. Set the gaps on the modulation transformer, 1T4, at 3/64 inch.

#### TUNING

Before actual tuning it is necessary to make certain coil and capacitor adjustments, and to install the frequency-determining components required for the assigned frequency. All circuit breakers and switches should be in the OFF position.

#### Component Adjustments

In the oscillator unit, connect the jumper on coil L1 to the position specified in Table 6. Refer to Figure 8 or 13 for coil location. After adjustment, replace the cover and install the oscillator unit in the cabinet. Using the bus supplied, item 12 of MI-27090-A, connect the oscillator output to the feed-through terminal between 1V1 and 1V2. This connection is wire 245 on Figure 14.

TABLE 6. OSCILLATOR COIL SETTINGS

FREQUENCY	JUMPER CONNECTION ON L1
535 to 700 kc 700 to 1,000 kc 1,000 to 1,300 kc 1,300 to 1,620 kc	Remove (use entire coil) Tap 2 Tap 3 Tap 4

At the rear of the transmitter, connect capacitors 1C5 and 1C6 and short-circuit turns on coil 1L3 as specified in Table 7. Refer to Figures 6, 7, and 15 for details.

TABLE 7. BUFFER TANK SETTINGS

FREQUENCY	ITEMS AND CONNECTIONS
535 to 750 kc 750 to 1,050 kc 1,050 to 1,620 kc	1C5 and 1C6 in parallel 1C6 (1C5 not used) 1C5 and 1C6 in series
<p>SETTINGS, SHORTING (LOWER) JUMPER ON 1L3</p>	
<p>Connect the coupling connection (upper) on 1L3 approximately 8 turns from shorting jumper, toward low-potential or left side of 1L3.</p>	

(8943601 sub 0)

Upon completing the adjustments in Table 7, make the jumper connection on 1L6 as specified in Figure 3. Coil 1L6 is indicated in Figure 7.

The frequency-determining capacitors are supplied as MI-27093 or MI-28096-A (BTA-500MX or BTA-1MX). These capacitors must be installed in varying values and combinations depending on the assigned frequency and the impedance of the transmission line and antenna network. Tables 8 and 9, for the BTA-500MX and BTA-1MX, respectively, cover the installation of these capacitors. Since the position of the shorting jumper on coil 1L7 also varies with the output impedance, this adjustment is also covered in Tables 8 and 9. The capacitors should be mounted at the upper rear of the unit, as shown in Figures 6 and 15. Mounting hardware is supplied as item 6 of MI-27090-A.

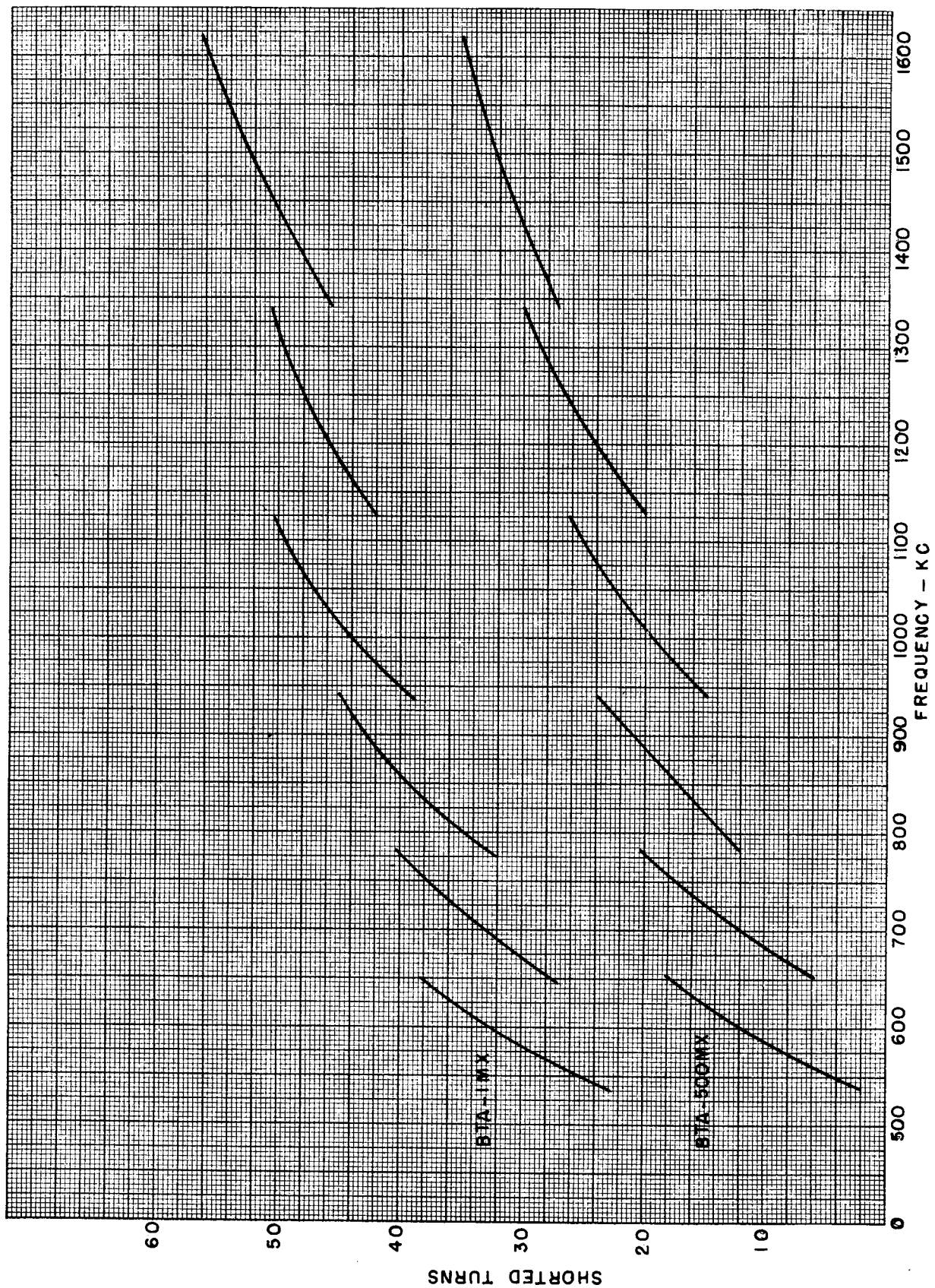

Figure 3. Tuning Chart, Jumper Connections on PA Tank Coil 1L6 (8943600 sub 0)

TABLE 8. BTA-500MX FREQUENCY-DETERMINING (F-D) PARTS

OUTPUT LINE (OHMS)	FREQUENCY (KC)	F-D PARTS, MI-27093-	CONNECT IN CIRCUIT		CONNECT IN PARALLEL		SHORTED TURNS ON 1L7 (APPROX.)
			*1C21		*1C23	*1C24	
51.5	535-650	item 1	510		15,000	15,000	9
	650-780	item 4	330		12,000	12,000	9
	780-940	item 7	56		10,000	10,000	9
	940-1120	item 10	-		8,200	10,000	9
	1120-1340	item 13	-		6,200	8,200	10
	1340-1620	item 16	-		6,200	6,200	11
72	535-650	item 2	510		10,000	12,000	9
	650-780	item 5	330		8,200	10,000	9
	780-940	item 8	56		6,200	8,200	10
	940-1120	item 11	-		6,200	6,200	10
	1120-1340	item 14	-		3,900	6,200	11
	1340-1620	item 17	-		3,000	6,200	11
230	535-650	item 3	510		3,000	3,900	3
	650-780	item 6	330		3,000	3,000	5
	780-940	item 9	56		2,000	3,000	7
	940-1120	item 12	-		2,000	2,000	7
	1120-1340	item 15	-		1,500	2,000	8
	1340-1620	item 18	-		1,500	1,500	9

\*Capacitor values in micromicrofarads.

TABLE 9. BTA-1MX FREQUENCY-DETERMINING (F-D) PARTS

OUTPUT LINE (OHMS)	FREQUENCY (KC)	F-D PARTS, MI-28096A-	CONNECT IN SERIES		CONNECT IN PARALLEL			SHORTED TURNS ON 1L7 (APPROX.)
			*1C21	*1C22	*1C23	*1C24	*1C25	
51.5	535-650	item 1	1,300	1,300	10,000	10,000	-	11
	650-780	item 4	620	1,000	8,200	8,200	-	11
	780-940	item 7	330	-	8,200	6,200	-	11
	940-1120	item 10	330	-	6,200	6,200	-	12
	1120-1340	item 13	100	-	6,200	3,900	-	12
	1340-1620	item 16	100	-	3,900	3,900	-	13
72	535-650	item 2	1,300	1,300	10,000	10,000	-	10
	650-780	item 5	620	1,000	8,200	8,200	-	11
	780-940	item 8	330	-	8,200	6,200	-	11
	940-1120	item 11	330	-	6,200	6,200	-	12
	1120-1340	item 14	100	-	3,900	3,900	-	12
	1340-1620	item 17	100	-	3,000	3,000	-	12
230	535-650	item 3	1,300	1,300	3,900	3,000	-	6
	650-780	item 6	620	1,000	3,000	3,000	-	8
	780-940	item 9	330	-	3,000	2,000	-	9
	940-1120	item 12	330	-	2,000	2,000	-	9
	1120-1340	item 15	100	-	1,500	1,500	510	10
	1340-1620	item 18	100	-	1,000	1,000	1,000	10

\*Capacitor values in micromicrofarads. -25-



Transmitter Tuning

Connect the primary leads on transformer 1T6 as specified in Table 4. Tune the BTA-500MX or BTA-1MX transmitter by following the step-by-step tuning procedure in Table 10.

TABLE 10. STEP-BY-STEP TUNING PROCEDURE, BTA-500MX AND BTA-1MX

STEP	SWITCHES OR BREAKERS		OPERATION	METER AND READING	REMARKS
	ITEM	POSITION			
- OSCILLATOR TUNING -					
1	BLOWER all others	ON OFF	Connect plate caps on 866A/ 866 tubes, 1V11 and 1V12. Remove buffer tubes 1V1 and 1V2 from sockets. Remove crystal from socket.		Close front and rear doors.
2	POWER CHANGE FILAMENT L. P. MOD. PA	DAY ON ON ON ON		FILAMENT (Table 4)	Allow plate time-delay relay 1K1 to close (30 seconds). POWER ON lamp glowing.
3	PLATE	ON	Place METER switch at OSC.	1M5, 60% approx.	PLATE ON lamp glowing. Reading supplies non- oscillating plate current, to check oscillator activity.
4	PLATE	OFF	Replace crystal in socket.		Allow 30-minute crystal warm-up before Step 5. CRYSTAL HEATER 1 and 2 lamps should glow intermittently.
5	PLATE	ON		1M5, 75% approx.	If reading is higher than 75%, operate PLATE breaker to OFF. Remove oscillator unit, and move jumper on L1 to next higher tap. Replace oscillator and operate PLATE breaker to ON. Check meter reading. Best tap position uses least number of active turns on L1 and results in increase of approxi- mately 15% in meter reading over Step 3. NOTE: Crystals are cali- brated for tuning on lower inductive side of resonance. Foregoing procedure will prevent improper starting and instability. Oscillator plate current increases above 15% may not provide sufficient drive for buffer.

Cont.

TABLE 10. STEP-BY-STEP TUNING PROCEDURE, BTA-500MX AND BTA-1MX (Cont.)

STEP	SWITCHES OR BREAKERS		OPERATION	METER AND READING	REMARKS
	ITEM	POSITION			
- BUFFER-DRIVER TUNING -					
6	PLATE	OFF	Replace tubes 1V1 and 1V2.		
7	PLATE	ON	Place METER switch at BUF. IG.	1M5, 100%	Reading shows relative strength of r-f signal into buffer.
8			Place METER switch at BUF. IKL then BUF. IKR. ("L" and "R" refer to tube at left or right, 1V1 or 1V2, respectively.)	1M5 (both readings about same)	Record meter readings for future comparison.
9	PLATE	OFF	Move shorting jumper on 1L3 1 turn in either direction.		See Table 7 for differentiation between shorting jumper and coupling connection on 1L3 (Step 12).
10	PLATE	ON	Place METER switch at BUF. IKL then BUF. IKR.	1M5	Compare new readings with Step 8. If lower, repeat Step 9, moving jumper in same direction. If higher, move jumper in opposite direction.
11					Repeat Steps 9 and 10 for jumper location which gives lowest meter reading.
12	PLATE	OFF	Move coupling connection on 1L3 1 turn to right.		
13	PLATE	ON	Place METER switch at PA IG.	1M5: BTA-500MX, 50-75% BTA-1MX, 100-125%.	Repeat Step 12 until further movement of coupling connection results in only small increase in meter reading. <b>CAUTION</b> Do not move coupling connection on 1L3 so that increased coupling (movement of connection to right) results in decreasing grid current.
- POWER AMPLIFIER TUNING -					
14	PLATE	OFF	Connect the primary leads on 1T11 in accordance with Table 4. Connect plate cap on rectifier 1V13, type 8008, but not on 1V14.		Not connecting plate cap on 1V14 results in reduced plate voltage (but poor regulation) for initial tuning.

Cont.

TABLE 10. STEP-BY-STEP TUNING PROCEDURE, BTA-500MX AND BTA-1MX (Cont.)

STEP	SWITCHES OR BREAKERS		OPERATION	METER AND READING	REMARKS
	ITEM	POSITION			
- POWER AMPLIFIER TUNING - (Cont.)					
15			Set PA TUNING knob at center of scale.		Setting of PA TUNING control as specified provides desirable starting point, since tuning must be performed rapidly when power is applied, to prevent tube damage.
16			Connect the output lead from 1L6 (coupling tap) to a point on 1L7 approximately 1/2 turn from grounded end of 1L7.		(1L6 is part of plate tank, which will be tuned for <u>minimum</u> plate current.)
17			Set at maximum counterclockwise position: POWER OUTPUT control Modulator bias pot. 1R54 Modulator bias pot. 1R55.		See Fig. 5 for location of 1R54, 1R55.
18			Connect transmitter output to suitable r-f load.		
19	PLATE	ON	Quickly adjust PA TUNING knob for minimum on PA PLATE CURRENT meter, approximately 0.1 to 0.2 ampere. Record meter reading.		If minimum meter reading is not obtained near midpoint of PA TUNING scale, see Step 20. If OK, proceed to Step 21.
20	PLATE	OFF	Move jumper on 1L6 one turn toward top of coil if minimum reading occurs near clockwise setting of knob, or toward bottom if minimum occurs near counterclockwise position.		Alternate Steps 19 and 20 until minimum meter reading occurs near midpoint of PA TUNING scale.
21	PLATE	OFF	Move shorting jumper on 1L7 approximately 1/4 turn in either direction.		(1L7 is harmonic filter, which will be adjusted for <u>maximum</u> plate current.)
22	PLATE	ON	Readjust PA TUNING knob for minimum on PA PLATE CURRENT meter. Compare meter reading with Step 19.		If current has increased over Step 19, alternate Steps 21 and 22, moving shorting jumper on 1L7 in same direction, in small increments, for maximum plate current. If current has decreased from Step 19, alternate Steps 21 and 22, moving shorting jumper on 1L7 in opposite direction, in small increments, for maximum plate current. Appreciable re-adjustment of PA TUNING knob, after moving jumper on 1L7, indicates over-coupling. In this event, see Step 23.

Cont.

TABLE 10. STEP-BY-STEP TUNING PROCEDURE, BTA-500MX AND BTA-1MX (Cont.)

STEP	SWITCHES OR BREAKERS		OPERATION	METER AND READING	REMARKS
	ITEM	POSITION			
- POWER AMPLIFIER TUNING - (Cont.)					
23	PLATE	OFF	If appreciable readjustment of PA TUNING is required in Step 22, move coupling tap on 1L7 closer to grounded end of 1L7.		Repeat Steps 21 and 22.
24	PLATE	OFF	Rotate POWER OUTPUT knob to center of range. Connect plate cap on 1V14.		
25	PLATE	ON	Readjust PA TUNING knob for minimum on PA PLATE CURRENT meter.		Repeat Steps 21 and 22 until r-f output is approximately 5% less than normal required output, when PA TUNING knob is adjusted for minimum plate current.
26			Rotate PA TUNING knob counterclockwise until normal output is obtained.	PA PLATE VOLTAGE, 2,550 volts. PA PLATE CURRENT: BTA-500MX, 275 ma. BTA-1MX, 0.55 amp. (approximately)	
27			Adjust bias potentiometers 1R54, 1R55.	1M5, 30%	Place METER switch first in MOD. R then in MOD. L position. Readings should be identical in both positions.
28			For any slight operating frequency correction, adjust crystal unit trimmer C1 (Fig. 5). Use insulated alignment tool.		Use frequency monitor. Capacitor C1 accessible through hole in front panel.
29			Record actual meter readings, coil tap positions, and tuning control settings for future reference.		Compare meter readings with Table 11 or 12.
30	PLATE	OFF	Connect jumper on secondary of 1T2 to tap 7. Adjust monitoring tap on 1L7 (the one from 1T2) to approximately 2 turns from grounded end of 1L7.		

Cont.

TABLE 10. STEP-BY-STEP TUNING PROCEDURE, BTA-500MX AND BTA-1MX (Cont.)

STEP	SWITCHES OR BREAKERS		OPERATION	METER AND READING	REMARKS
	ITEM	POSITION			
- POWER AMPLIFIER TUNING - (Cont.)					
31	PLATE	ON	Check level on modulation monitor.		Repeat Steps 30 and 31 as necessary to obtain proper output for modulation monitor. Use monitoring tap on 1L7 at point above ground just sufficient for required output.
32			Check arc-gap spacing on modulation transformer 1T4.		Adjust spacing until gaps flash over occasionally on 100% modulation peaks. Then increase spacing slightly beyond this point.
33	FILAMENT	OFF	Shut down transmitter.		This completes tuning for full-power output. Disconnect r-f load and connect antenna transmission line.

Reduced-Power Operation

Reduced-power operation requires the optional power-change kit, MI-28099, which should have previously been installed as instructed. This kit makes it possible to operate POWER CHANGE switch 1S11 to the NIGHT position and simultaneously reduce the plate voltage on the modulator and PA stages. Before reduced-power operation is attempted, it is necessary first that the transmitter be completely adjusted for full-power output as specified in Table 10. The only step required for reduced output is the placing of switch 1S11 in the NIGHT position and recording the meter readings, which should be checked against Table 11 or 12.

Adjusting Antenna Arc-Gaps

If arc-gaps are installed across the antenna base insulators, these gaps should be carefully adjusted to obtain protection during excessively dusty or humid weather conditions. Set the arc-gap spacing so that flashover occurs just beyond the point of 100 percent sine wave modulation.



TABLE 12. TYPICAL PANEL METER READINGS, BTA-1MX

METER SYMBOL	PANEL DESIGNATION	MODULATION PERCENTAGE		ACTUAL CURRENTS AT 100% METER READING
		0%	100%	
- FULL-POWER OUTPUT, 1,000 WATTS -				
1M1 1M2 1M3 1M4 1M5	FILAMENT VOLTAGE PA PLATE VOLTAGE PA PLATE CURRENT ANTENNA CURRENT METER: 1ST AF IKR 1ST AF IKL 2ND AF IBR 2ND AF IBL MOD R MOD L OSC BUF IG BUF IKR BUF IKL PA IG PA IKR PA IKL	See Table 4. 2,550 volts 0.55 amp. - 100% 100% 75% 75% 30% 30% 75% 100% 100% 100% 100% 100% 100% 100%	- - 100% 100%	4.9 ma 4.9 ma 25 ma 25 ma 300 ma 300 ma 37 ma 8 ma 100 ma 100 ma 148 ma 345 ma 345 ma
- REDUCED-POWER OPERATION, 500 WATTS - (Approximate resistance of power-change kit 1,920 ohms)				
1M1 1M2 1M3 1M4 1M5	FILAMENT VOLTAGE PA PLATE VOLTAGE PA PLATE CURRENT ANTENNA CURRENT METER: 1ST AF IKR 1ST AF IKL 2ND AF IBR 2ND AF IBL MOD R MOD L OSC BUF IG BUF IKR BUF IKL PA IG PA IKR PA IKL	See Table 4. 1,800 volts 0.39 amp. - 100% 100% 75% 75% 30% 30% 75% 100% 100% 100% 100% 70% 70%	- 70% 70%	4.9 ma 4.9 ma 25 ma 25 ma 300 ma 300 ma 37 ma 8 ma 100 ma 100 ma 148 ma 345 ma 345 ma
- REDUCED-POWER OPERATION, 250 WATTS - (Approximate resistance of power-change kit 4,605 ohms)				
1M1 1M2 1M3 1M4 1M5	FILAMENT VOLTAGE PA PLATE VOLTAGE PA PLATE CURRENT ANTENNA CURRENT METER: 1ST AF IKR 1ST AF IKL 2ND AF IBR 2ND AF IBL MOD R MOD L OSC BUF IG BUF IKR BUF IKL PA IG PA IKR PA IKL	See Table 4. 1,275 volts 0.275 amp. - 100% 100% 75% 75% 30% 30% 75% 100% 100% 100% 100% 60% 60%	- 50% 50%	4.9 ma 4.9 ma 25 ma 25 ma 300 ma 300 ma 37 ma 8 ma 100 ma 100 ma 148 ma 345 ma 345 ma

## OPERATION

### ROUTINE OPERATION

In routine operation, it is necessary to operate only the **FILAMENT** circuit breaker for starting and stopping the transmitter. All other circuit breakers and switches should be left in the **ON** position at the end of each shut-down.

Where unusual conditions make it desirable to employ additional heating time for the rectifier tube filaments, before the application of plate voltage, keep the **PLATE** breaker in the **OFF** position. After the required interval, operate the **PLATE** breaker to the **ON** position. Normally, sufficient warm-up time is provided by the plate time-delay relay.

To interrupt transmission for a short interval, operate the **PLATE** breaker to **OFF**. This will maintain filament power on the tubes, and the transmitter will be returned to immediate operation when the **PLATE** breaker is closed.

For stability, the crystal units are intended to be operated at all times, except when the transmitter is to be shut down for extended periods. Therefore, the external switch controlling crystal heater power should not be opened at routine shut-downs. The crystal units require a minimum of 30 minutes warm-up time before operating the transmitter.

At start-up, and at regular intervals during operation, note and record the panel meter readings in a suitable log. This will aid in maintaining the proper operating conditions, and will disclose irregularities and gradual changes which indicate the need for tube replacement. Refer to Table 11 or 12 for typical panel meter readings.

### OVERLOADS AND INTERRUPTIONS

If an overload occurs, and the overload persists for more than approximately two seconds, plate power will be removed from the transmitter. After the overload source has been located and the necessary corrective action taken, the transmitter will automatically be returned to operation if all switches and breakers are closed.

In the event of power-line interruptions, the transmitter will be shut down for the period of interruption, but will be returned to operation automatically after the required interval for filament warm-up and time-delay relay operation.

### REDUCED-POWER OPERATION

Reduced-power operation, for "day-night" transmission, is provided when the optional MI-28099 kit is installed. Power reduction, or increase, is achieved merely by operating the **POWER** switch to either the **DAY** or **NIGHT** position-as desired.

### FUSES

In addition to the overload relays and circuit breakers, fuses are utilized in the power input to the crystal heaters and for protection of the cabinet lighting circuits. These fuses are as follows:

<u>ITEM</u>	<u>RATING</u>
1F1, 1F2	1 ampere
1F3, 1F4	2 amperes

All fuses are located just above the center dividing shelf, behind the front door.



## MAINTENANCE

### GENERAL

With ordinary care a minimum of service will be required to keep the BTA-500MX or BTA-1MX transmitters in operation. To avoid interruptions during broadcasts, however, a regular schedule of inspection should be established. Table 13, a recommended schedule for the transmitter, should be correlated with other station equipment maintenance to insure overall peak efficiency.

Always open the FILAMENT circuit breaker and discharge circuits with a grounding stick before touching any component.

TABLE 13. RECOMMENDED OVERALL MAINTENANCE SCHEDULE

- DAILY -
<ul style="list-style-type: none"><li>- Check and compare all meter readings at start-up. Adjust filament voltages if necessary. Take steps to correct any condition revealed by abnormal reading.</li><li>- Check filament voltages every hour, for increased tube life.</li><li>- Make general visual inspection after shut-down.</li><li>- If overloads have occurred, examine components concerned at shut-down, and repair or replace as necessary.</li></ul>
- WEEKLY -
<ul style="list-style-type: none"><li>- Clean internal parts of transmitter. Use clean, soft cloth on insulators. Use vacuum cleaner or hand blower for removing dust or dirt.</li><li>- Test all door interlocks and grounding switches.</li><li>- Check PA and output r-f circuits for evidence of heating at connector or junction points.</li><li>- Make overall check on distortion and noise level.</li></ul>
- MONTHLY -
<ul style="list-style-type: none"><li>- Check spare crystal in operating crystal socket.</li><li>- Check condition of relay contacts. Service if necessary.</li><li>- Check and record tube socket voltages in audio section. Compare with previous readings to detect irregularities.</li><li>- Inspect air filter. Clean, if necessary, using vacuum cleaner or brush.</li></ul>

TABLE 13. RECOMMENDED OVERALL MAINTENANCE SCHEDULE (cont'd)

- QUARTERLY -
<ul style="list-style-type: none"> <li>- Operate all spare mercury-vapor rectifier tubes for 30 minutes, filament only.</li> <li>- Lubricate blower motor 1B1. Use a few drops of SAE 30 oil.</li> <li>- Lubricate all tuning drive mechanism gears and bearings. Use petrolatum, Lubriplate No. 110, or equivalent.</li> <li>- Clean air filter. See heading "Air Filter."</li> </ul>
- SEMI-ANNUALLY -
<ul style="list-style-type: none"> <li>- Inspect relay contacts and replace where required.</li> <li>- Test spare tubes.</li> <li>- Tighten all connections in transmitter.</li> </ul>

#### CLEANING

Ceramic insulators and bushings should be kept clean at all times. Insulators subject to stress in high-voltage d-c fields may rupture if sufficient dust accumulates to cause a corona discharge. Clean insulators by using a soft clean cloth and carbon tetrachloride.

Keep tube envelopes clean to avoid possible puncture of the glass due to ion bombardment or corona. Tissue paper and alcohol are effective for this purpose.

Clean plate tank coils with a dry cloth. **NEVER USE LIQUID POLISH OR STEEL WOOL ON THESE ITEMS.** Avoid any scratches on the silver-plated surfaces.

Keep safety gaps clean. If gaps are pitted, polish them with crocus cloth.

#### AIR FILTER

The air filter is of the all-metal type and is designed for cleaning and re-oiling when dirty. The filter should be cleaned at intervals of one to three months, depending upon local atmospheric conditions. A vacuum cleaner or brush may be used to remove most loose deposits. Commercial facilities are generally available which will clean and re-oil the filter for a small fee.

To clean the air filter, take the filter element out of the frame. Tap the element on a hard surface several times to remove any loose accumulations. Wash the element in a pan of hot water and a mild household detergent, or use a jet of live steam. Rinse and dry the element thoroughly.

Re-oil the filter by applying a coating such as "Filter Kote" (manufactured by Air Maze Corporation of Cleveland, Ohio) or pure SAE no. 30 motor oil. The oil may be sprayed on, or the element may be dipped into the oil. After coating, allow the element to drain thoroughly in a warm room before reinstalling.

## CIRCUIT BREAKERS AND RELAYS

GI  
B.  
re  
fo  
ov  
be

Periodic inspection of circuit breakers and relays should be made, and at such time all contacts should be cleaned and adjusted if necessary.

The circuit breakers in this transmitter have contacts made of a material which does not require dressing even though severely pitted. Contacts may be cleaned with carbon tetrachloride and a soft cloth. Keep the pole faces clean and see that they seat securely. Check the operation manually, and tighten any loose screws.

Relay contacts should be cleaned with carbon tetrachloride applied with a soft brush, after which they should be burnished with a tool such as the RCA stock No. 22963 Contact Cleaning Tool. Finally, contacts should be wiped with a clean piece of bond paper.

## TUBES

Check all tubes periodically. Tube failure can be anticipated by keeping a log of tube life and replacing tubes when indicated by the log or when reduced output is apparent.

Before use, each spare mercury-vapor rectifier tube should be conditioned or "seasoned" by operating it for a minimum of 30 minutes with only filament voltage applied. Store the tubes in an upright position afterward. Take care to avoid tipping the tube or splashing mercury on the tube elements after "seasoning." If mercury is splashed on the elements, it will be necessary to re-season the tube. Spare mercury-vapor rectifier tubes should also be seasoned every three months due to gradual absorption of mercury-vapor by the filament.

## ANTENNA CURRENT READINGS

Under certain circumstances, when the tower lights are on, the 60-cycle tower lighting current may cause fluctuation or inaccuracies in the antenna current meter reading. This condition is created when the tower itself serves as one side of the lighting circuit and, hence, provides a common path for the tower lighting current and the r-f current. Where this situation exists, it is possible to have two ground return paths for the 60-cycle lighting current: one through the antenna coupling equipment and transmitter output circuit, the other in the a-c lighting circuit through the tower lighting chokes to ground where one side of the a-c is grounded. A simplified schematic diagram of a typical circuit illustrating this possibility is shown in Figure 4. To prevent the meter fluctuations, it is necessary for the 60-cycle tower lighting current to be returned via a path other than the r-f circuits feeding the tower.

If a toroidal tower lighting transformer is used, no antenna current meter fluctuations will occur. Where lighting chokes are utilized, the circuit should be checked for the existence of a second ground path as previously described.

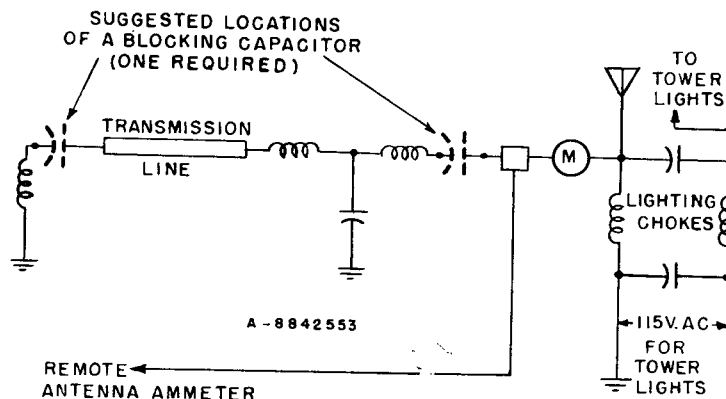

Figure 4. Typical Tower Lighting Circuit (8842553 sub 1)

Elimination of the 60-cycle return path through the coupling equipment or transmitter output circuit is achieved by inserting a blocking capacitor in the antenna feed line. The capacitor may be connected in either of two places, just ahead of the antenna current meter or between the transmitter output and the transmission line. The location depends upon the type of coupling circuit used in the line terminating unit. As a general rule, the reactance of the blocking capacitor, shown dotted in Figure 4, should be not greater than approximately one-tenth the characteristic impedance of the transmission line.

To determine whether antenna current meter variations are caused by the condition just described, turn on the tower lights while the transmitter is off. The presence of any current reading on the antenna current meter at this time indicates the need for corrective measures.

### TUBE SOCKET VOLTAGES

Typical tube socket voltages are supplied in Table 14.

TABLE 14. TYPICAL TUBE SOCKET VOLTAGES, BTA-500MX AND BTA-1MX

Tube Symbol	Tube Function	Tube Type	Plate		Cathode		Grid		Screen		Filament	
			Pin No.	Volts DC	Pin No.	Volts DC	Pin No.	Volts DC	Pin No.	Volts DC	Pin No.	Volts AC
V1	Oscillator	807	cap	270	4	20	3	-	2	270	1-5	6.3
1V1,1V2	Buffer/Driver	807	cap	530	4	1.7	3	-75	2	270	1-5	6.3
1V3,1V4	PA	833A										
		1000 watts output:		2550	-	-	-	-120	-	-	top	10
	BTA-1MX	500 watts output:		1800	-	-	-	-120	-	-		10
		250 watts output:		1275	-	-	-	-120	-	-		10
		500 watts output:		2550	-	-	-	-120	-	-		10
	BTA-500MX	250 watts output:		1800	-	-	-	-120	-	-		10
1V5,1V6	1st AF	807	cap	155	4	38	3	17	2	190	1-5	6.3
1V7,1V8	2nd AF	807	cap	530	4	-58	3	-75	2	160	1-5	6.3
1V9,1V10	Modulator	833A		2550	-	-	-	-58	-	-	top	10
1V11,1V12	LV Rectifier	866A/866	cap	660ac	-	-	-	-	-	-	1-4	2.5
1V13,1V14	HV Rectifier	8008	cap	3100ac	-	-	-	-	-	-	2-3	5

All voltages dc and measured to ground unless otherwise noted. Measurements made with high-resistance voltmeter.

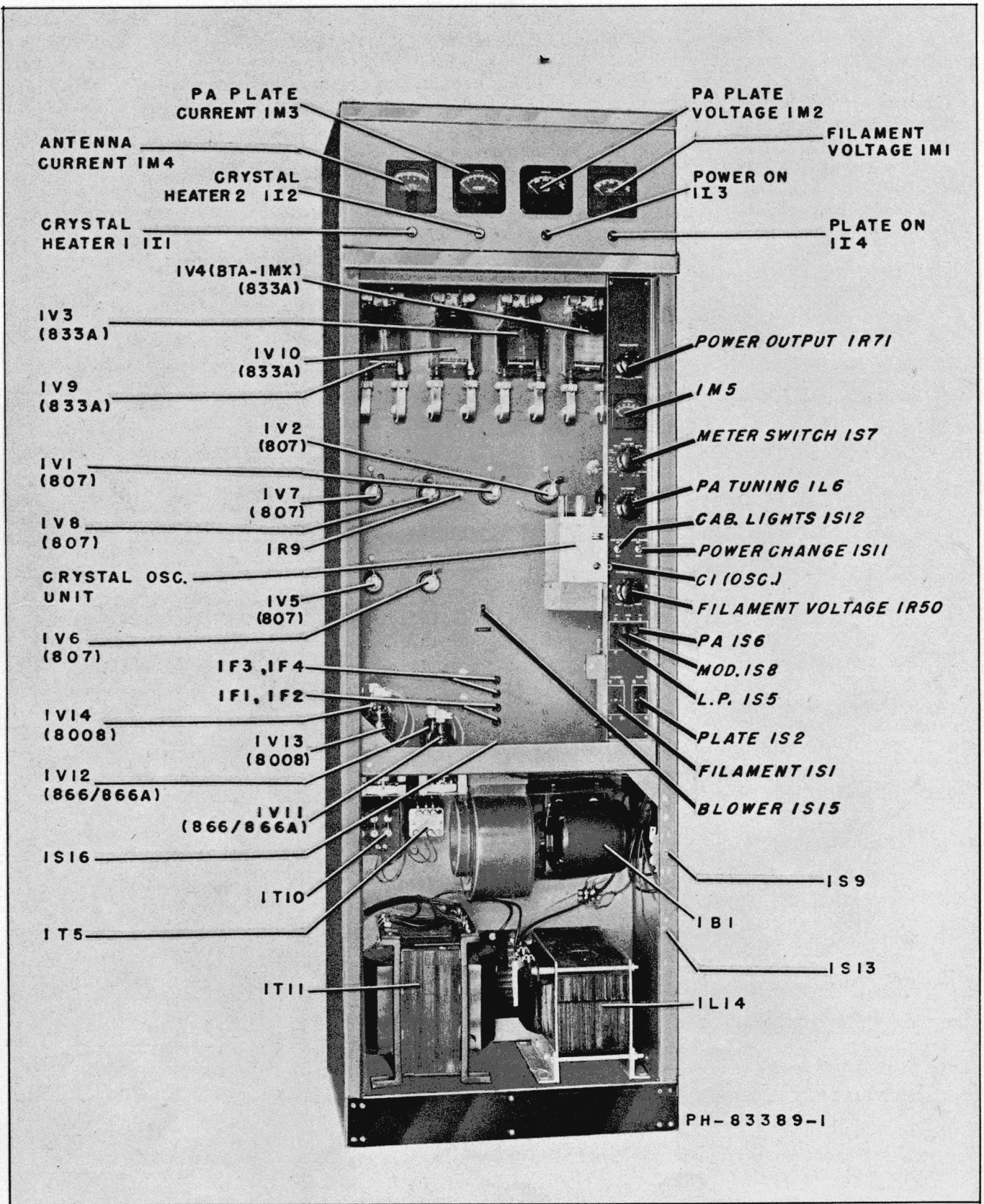

Figure 5. Transmitter, Front View



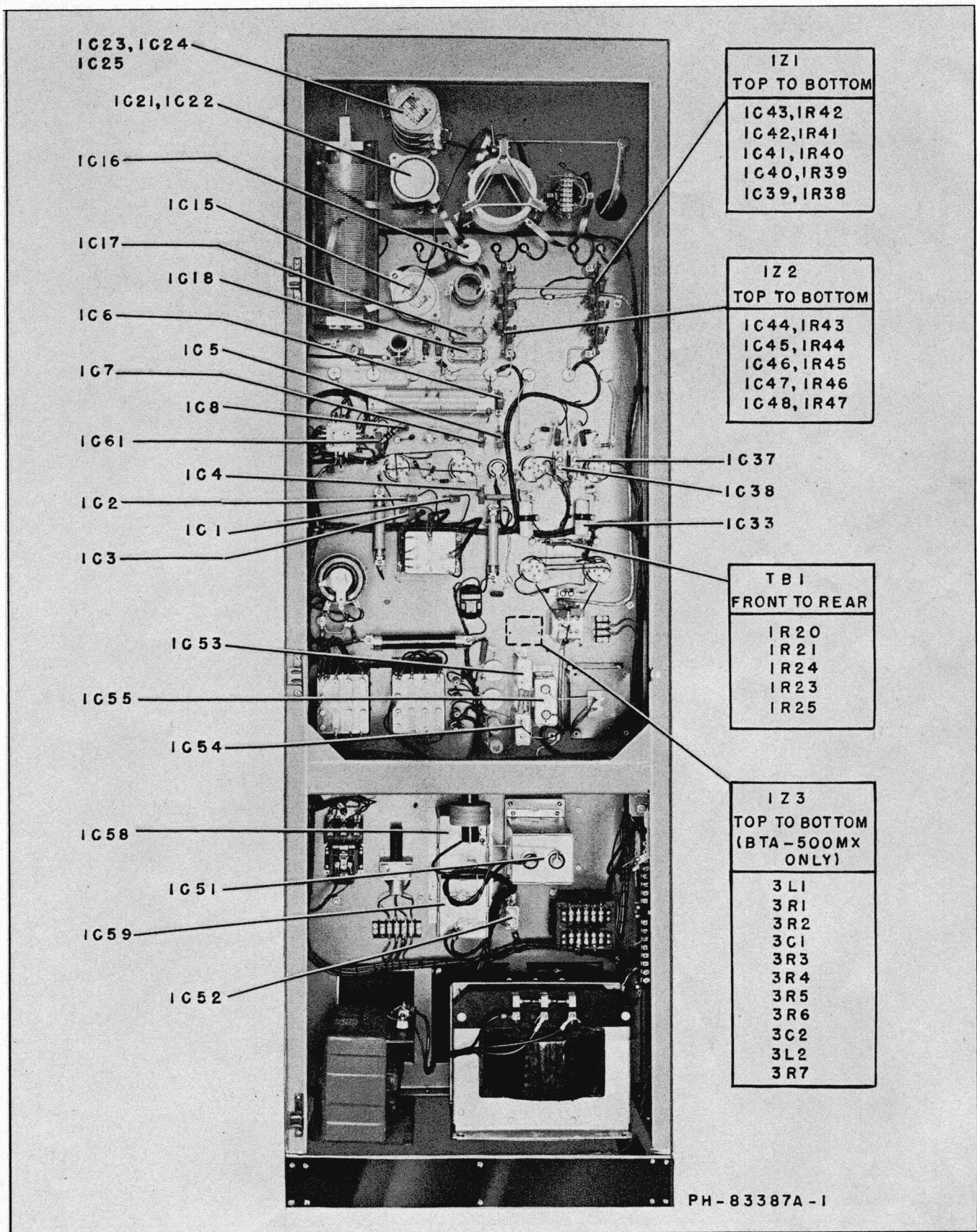

Figure 6. Transmitter, Rear View, Part I





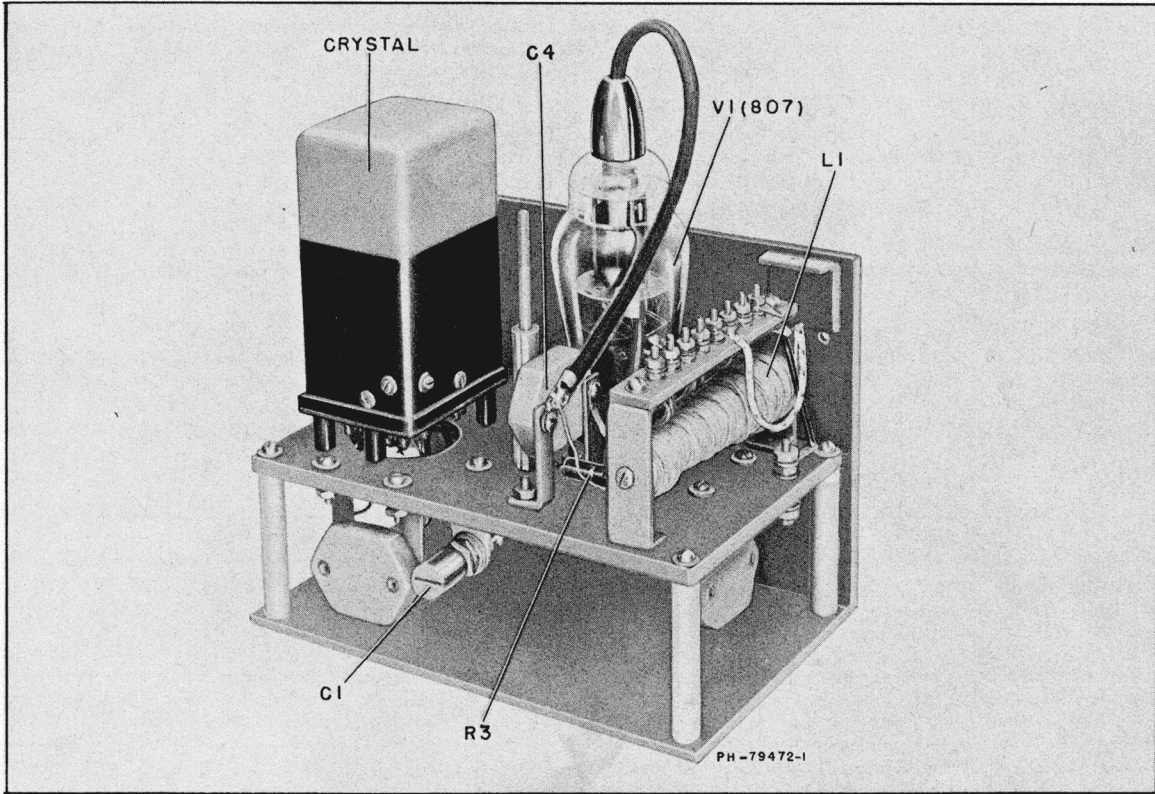

Figure 8. Oscillator, Above Chassis View

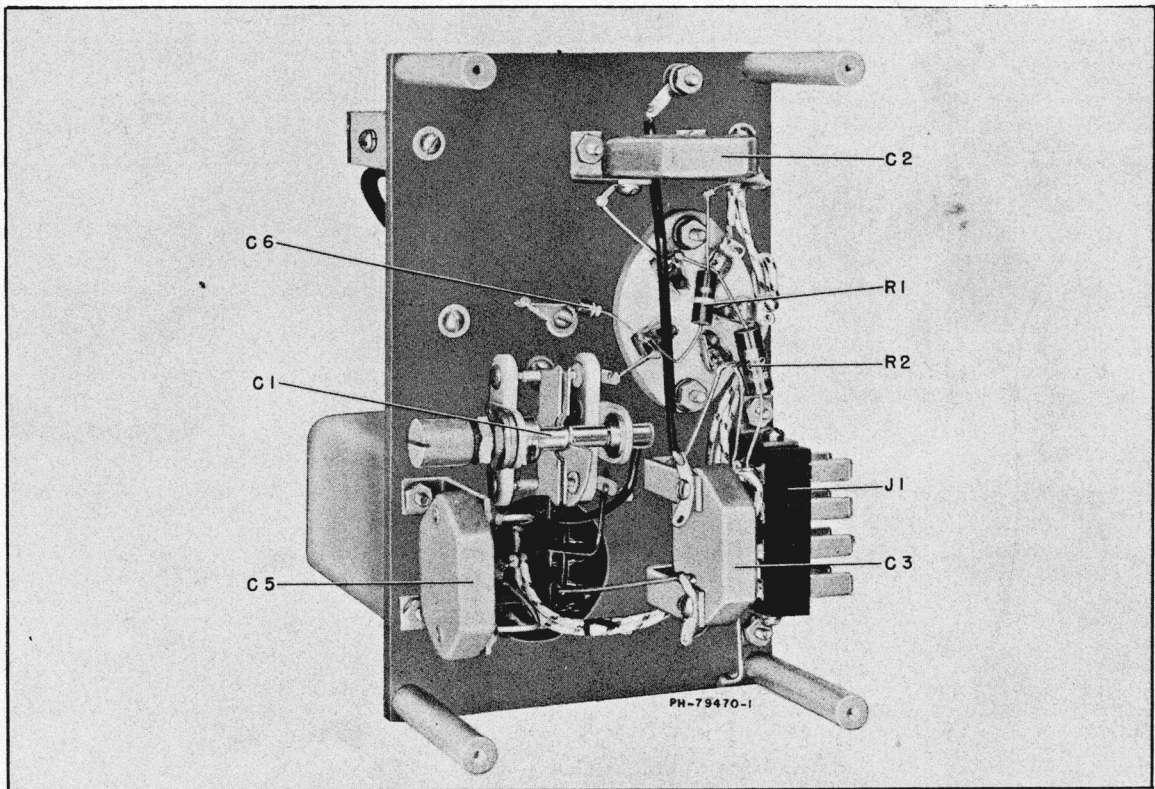

Figure 9. Oscillator, Below Chassis View



## EQUIPMENT LOST OR DAMAGED IN TRANSIT

When delivering the equipment to you, the truck driver or carrier's agent will present a receipt for your signature. Do not sign it until you have (a) inspected the containers for visible signs of damage and (b) counted the containers and compared with the amount shown on the shipping papers. If a shortage or if evidence of damage is noted, insist that notation to that effect be made on the shipping papers before you sign them.

Further, after receiving the equipment, unpack it and inspect thoroughly for concealed damage. If concealed damage is discovered, immediately notify the carrier, confirming the notification in writing, and secure an inspection report. This item should be unpacked and inspected for damage WITHIN 15 DAYS after receipt.

Report all shortages and damages to RCA, Broadcast and Television Department, Camden 2, N. J.

Radio Corporation of America will file all claims for loss and damage on this equipment so long as the inspection report is obtained. Disposition of the damaged item will be furnished by RCA.

## REPLACEMENT PARTS AND ENGINEERING SERVICE

RCA field engineering service is available at current rates. Requests for field engineering service may be addressed to your RCA Broadcast Field Representative or the RCA Service Company, Inc., Broadcast Service Division, Camden, N. J. Telephone: WOODLAWN 3-8000.

When ordering replacement parts, please give symbol, description, and stock number of each item ordered.

The part which will be supplied against an order for a replacement item may not be an exact duplicate of the original part. However, it will be a satisfactory replacement differing only in minor mechanical or electrical characteristics. Such differences will in no way impair the operation of the equipment.

The following tabulations list service parts and electron tube ordering instructions according to your geographical location.

### SERVICE PARTS

LOCATION	ORDER SERVICE PARTS FROM:
Continental United States, including Alaska and Hawaii	RCA Electron Tube Division, Parts and Equipment, P.O. Box 654, Camden, New Jersey or through your nearest RCA Regional Office. Emergency orders may be telephoned, telegraphed, or teletyped to RCA Emergency Service, Bldg. 60, Camden, N. J. (Telephone: WO 3-8000).
Dominion of Canada	RCA Victor Company Limited, 1001 Lenoir Street, Montreal, Quebec or through your local Sales Representative or his office.
Outside of Continental United States, Alaska, Hawaii and the Dominion of Canada	RCA International Division, Clark, N. J., U.S.A. or through your local Sales Representative.

### ELECTRON TUBES

LOCATION	ORDER ELECTRON TUBES FROM:
Continental United States, including Alaska and Hawaii	Local RCA Tube Distributor.
Dominion of Canada	RCA Victor Company Limited, 1001 Lenoir Street, Montreal, Quebec or through your local Sales Representative or his office.
Outside of Continental United States, Alaska, Hawaii and the Dominion of Canada	Local RCA Tube Distributor or from: Tube Department RCA International Division 30 Rockefeller Plaza New York 20, New York, U.S.A.

### RETURN OF ELECTRON TUBES

If for any reason, it is desired to return tubes, please return them through your local RCA tube distributor, RCA Victor Co. Ltd., or RCA International Div., depending on your location.

**PLEASE DO NOT RETURN TUBES DIRECTLY TO RCA WITHOUT AUTHORIZATION AND SHIPPING INSTRUCTIONS.**

It is important that complete information regarding each tube (including type, serial number, hours of service and reason for its return) be given.

When tubes are returned, they should be shipped to the address specified on the Return Authorization form. A copy of the Return Authorization and also a Service Report for each tube should be packed with the tubes.

### LIST OF RCA REGIONAL OFFICES

<p><i>Atlanta 3, Georgia</i> 1121 Rhodes-Haverty Bldg. 134 Peachtree St. N.W. JACKSON 4-7703</p>	<p><i>Boston 16, Mass.</i> Room 2301, John Hancock Bldg. 200 Berkley St. HUBBARD 2-1700</p>	<p><i>Chicago 54, Ill.</i> 1186 Merchandise Mart Plaza DELAWARE 7-0700</p>	<p><i>Cleveland 15, Ohio</i> 1600 Keith Bldg. CHERRY 1-3450</p>
<p><i>Dallas 35, Texas</i> 7901 Empire Freeway FLEETWOOD 2-3911</p>	<p><i>Hollywood 28, Calif.</i> RCA Bldg., 1560 N. Vine St. HOLLYWOOD 9-2154</p>	<p><i>Kansas City 6, Missouri</i> 340 Home Savings Bldg. HARRISON 1-6480</p>	<p><i>New York 20, New York</i> 36 W. 49th St. JUDSON 6-3800</p>
<p><i>Branch—San Francisco 2, Calif.</i> 420 Taylor St. ORDWAY 3-8027</p>		<p><i>Seattle, Washington</i> 2250 First Ave., S. MAIN 2-8350</p>	

## PARTS LIST

For ordering information see page 42.

SYMBOL NO.	DESCRIPTION	DRAWING NO.	STOCK NO.
<b>CRYSTAL OSCILLATOR UNIT, MI-19458</b>			
C1	Capacitor: crystal tuning, 5.3-20 mmf -----	823075-3	16890
C2, C3	Capacitor: by-pass, 0.01 mf $\pm 10\%$ , 1200 v -----	32203-591	610003
C4	Capacitor: output coupling, 47 mmf $\pm 5\%$ , 2500 v -----	32200-515	50358
C5	Capacitor: filter, 0.002 mf $\pm 5\%$ , 2500 v -----	32202-558	602002
C6	Capacitor: feedback, 1 mmf $\pm 10\%$ -----	99327-12	55331
J1	Plug: power, 8-prong -----	842766-1	47317
L1	Inductor: plate tank -----	429932-501	50360
R1	Resistor: grid leak, 150,000 ohm, $\pm 5\%$ , 1 w -----	722337-211	512415
R2	Resistor: cathode, 680 ohm, $\pm 5\%$ , 2 w -----	722357-155	522168
R3	Resistor: parasitic suppressor, 12 ohm, 1 w -----	727836-39	512012
X1	Socket: tube, RCA 807 -----	843314-2	9920
X2	Socket: crystal unit -----	409582-501	16889
<b>BTA-500MX/1MX BASIC TRANSMITTER, MI-27090-A</b>			
1B1	Motor: blower, 1140 RPM, 220 v, single phase, 60 cycle, AC current, 1/20 HP 1/2" shaft ----- 5/8" shaft -----	744420-4 744420-4	210361 210362
1C1 to 1C3	Capacitor: fixed, mica, 0.01 mf $\pm 20\%$ , 1200 v -----	728647-65	610003
1C4	Capacitor: fixed, mica, 1000 mf $\pm 20\%$ , 2500 v -----	728647-41	601002
1C5, 1C6	Capacitor: fixed, mica, 620 mmf $\pm 5\%$ , 3500 v -----	8843560-7	93930
1C7	Capacitor: fixed, mica, 4700 mmf $\pm 10\%$ , 1200 v -----	728647-157	95215
1C8, 1C9	Capacitor: fixed, mica, 0.01 mf $\pm 20\%$ , 1200 v. Same as 1C1 -----	728647-65	610003
1C10	Not Used		
1C11, 1C12	Capacitor: fixed, mica, 3300 mmf $\pm 20\%$ , 2500 v -----	728647-53	94171
1C13, 1C14	See Power-Determining Parts (BTA-1MX).		
1C15	Capacitor: fixed, mica, 510 mmf $\pm 5\%$ , 10,000 v -----	32228-627	94881
1C16	Capacitor: fixed, ceramic, 200 mmf, 10,000 v -----	8889035-1	94172
1C17	Capacitor: fixed, mica, 2000 mmf $\pm 5\%$ , 5000 v -----	32222-574	553054
1C18	Capacitor: fixed, mica, 300 mmf $\pm 5\%$ , 5000 v -----	32221-532	553109
1C19	Not Used		
1C20	See Power-Determining Parts.		
1C21 to 1C26	See Frequency-Determining Parts.		
1C27, 1C28	Capacitor: fixed, mica, 0.01 mf $\pm 20\%$ , 1200 v -----	36655-503	610003
1C29	Capacitor: fixed, paper, 0.05-0.05 mf $\pm 20\%$ , 600 v -----	984618-572	93626
1C30	Capacitor: fixed, mica, 4700 mmf $\pm 20\%$ , 1200 v -----	728651-57	95215
1C31, 1C32	Capacitor: fixed, mica, 270 mmf $\pm 5\%$ , 1000 v -----	727876-233	94174
1C33	Capacitor: fixed, paper, 1 mf $\pm 10\%$ , 600 v -----	984688-8	56124
1C34	Not Used		
1C35, 1C36	Capacitor: fixed, paper, 0.25 mf $\pm 10\%$ , 1000 v -----	984643-26	95214
1C37, 1C38	Capacitor: fixed, paper, 1 mf $\pm 10\%$ , 600 v. Same as 1C33 -----	984688-8	56124
1C39 to 1C42	Capacitor: fixed, mica, 510 mmf $\pm 5\%$ , 2500 v -----	728647-234	94164
1C43, 1C44	Capacitor: fixed, mica, 18,000 mmf $\pm 5\%$ , 600 v -----	728647-271	94165
1C45 to 1C48	Capacitor: fixed, mica, 510 mmf $\pm 5\%$ , 2500 v. Same as 1C39 -----	728647-234	94164
1C49 to 1C50	Not Used		
1C51	See Power-Determining Parts.		
1C52	Capacitor: fixed, paper, 1 mf $\pm 10\%$ , 1000 v -----	984621-12	18023
1C53, 1C54	Capacitor: fixed, oil, 10 mf, 400 v -----	450184-4	57017
1C55	Capacitor: fixed, paper, 15 mf $\pm 10\%$ , 600 v -----	990193-10	208749
1C56, 1C57	Capacitor: fixed, mica, 0.01 mf $\pm 20\%$ , 1200 v. Same as 1C27 -----	36655-503	610003
1C58, 1C59	Capacitor: fixed, paper, 6 mf $\pm 10\%$ , 3000 v -----	990193-107	95788
1C60	Capacitor: fixed, mica, 0.01 mf $\pm 20\%$ , 1200 v. Same as 1C27 -----	36655-503	610003
1C61	Capacitor: fixed, mica, 0.01 mf $\pm 20\%$ , 1200 v. Same as 1C1 -----	728647-65	610003
1CR1, 1CR2	Rectifier: bias, selenium, 20 cells -----	459484-1	94948
1F1, 1F2	Fuse: crystal heater, 1 amp -----	850339-6	19335
1F3, 1F4	Fuse: cabinet light, 2 amp -----	850339-8	45532
1I1 to 1I4	Lamp: indicator, for "crystal heater," "power on," "plate on" (lamp only) -----	459610-36	16154
	Jewel - indicator, white, for "crystal heater" -----	459610-34	99738
	Jewel - indicator, red, for "plate on" -----	459610-31	99765
	Jewel - indicator, green, for "power on" -----	459610-32	99766
	Receptacle, indicator lamp -----	459610-46	99763
	Resistor, 6300 ohm, for red and green indicator lamps -----	459610-41	44570
	Resistor, 2800 ohm, for white indicator lamp -----	459610-40	16155
1I5, 1I6	Lamp: lumiline interior, 115 v. ac -----	885232-2	93916

For ordering information see page 42 .

SYMBOL NO.	DESCRIPTION	DRAWING NO.	STOCK NO.
1J1, 1J2	Receptacle: r-f freq. mon., single-contact (male), chassis -----	255223-2	51800
1J3	Receptacle: crystal osc., 8-contact (male), chassis -----	842766-2	56751
1K1	Relay: plate time delay, coil 220 v., 50/60 cycle, 1 contact normally open -----	429587-1	44549
1K2	Contact: plate -----	8832129-3	94361
	Coil -----	8832129-29	205263
	Contact - movable -----	8832129-32	205267
	Contact - stationary, rear -----	8832129-35	205265
	Contact - stationary, front -----	8832129-36	205266
1L1, 1L2	Suppressor: parasitic, with 47 ohm, 2 w resistor -----	8883316-501	93934
1L3	Coil: buffer tank -----	740447-501	94064
1L4	Coil: PA grid -----	412784-501	16892
1L5	Coil: PA plate -----	418486-501	19185
1L6	Coil: inductor, PA tank -----	740486-502	208885
1L7	Coil: PA loading -----	740451-5	94938
1L8, 1L9	Not Used		
1L10, 1L11	Suppressor: parasitic, with 47 ohm, 2 w resistor. Same as 1L1 ---	8883316-501	93934
1L12	Reactor: L. V. filter, 10 henry -----	949251-1	93658
1L13, 1L14	See Power-Determining Parts.		
1L15	Reactor: buffer plate -----	884432-3	95881
1L16	Reactor: modulator output -----	450257-502	204689
1M1	Meter: 300 v. ac -----	459672-29	209818
1M2	Meter: 0-4 kv, dc -----	482744-2	211713
1M3	See Power-Determining Parts.		
1M4	Meter: MI-7157F r-f output ammeter or MI-28037 remote r-f antenna ammeter, scale range as required.		
1M5	Meter: 0-150% scale calib. -----	457507-9	93614
1P1, 1P2	Plug: r-f frequency monitor -----	252868-1	66344
1R1, 1R2	Resistor: fixed, composition, 47 ohm $\pm 5\%$ , 2 w -----	99126-5	522047
1R3	Resistor: fixed, composition, 10,000 ohm $\pm 5\%$ , 2 w -----	99126-74	522310
1R4	Resistor: fixed, wire wound, 25,000 ohm $\pm 5\%$ , 10 w -----	458574-72	208753
1R5	Resistor: fixed, wire wound, 33,000 ohm $\pm 5\%$ , 10 w -----	458574-85	44893
1R6	Resistor: fixed, wire wound, 18,000 ohm $\pm 10\%$ , 2 w -----	99126-77	522318
1R7, 1R8	Resistor: fixed, composition, 47 ohm $\pm 5\%$ , 2 w. Same as 1R1 -----	99126-5	522047
1R9	Resistor: variable, 1000 ohm -----	415457-14	19203
1R10	See Power-Determining Parts.		
1R11, 1R12	Resistor: fixed, composition, 27 ohm $\pm 10\%$ , 2 w -----	99126-43	522027
1R13	Resistor: 4 meg, 4000 v -----	878811-9	94414
1R14	Resistor: fixed, composition, 100,000 ohm $\pm 5\%$ , 2 w -----	99126-25	522410
1R15	Resistor: fixed, composition, 18,000 ohm $\pm 5\%$ , 10 w -----	443853-41	93634
1R16	Resistor: fixed, wire wound, 6300 ohm, 45 w -----	99029-39	94752
1R17, 1R18	Resistor: fixed, composition, 33,000 ohm $\pm 5\%$ , 1 w -----	90496-195	512333
1R19	Resistor: 82,000 ohm $\pm 5\%$ , 2 w -----	99126-85	522382
1R20, 1R21	Resistor: 47,000 ohm $\pm 5\%$ , 2 w -----	99126-82	44211
1R22	Not Used		
1R23, 1R24	Resistor: 47,000 ohm $\pm 5\%$ , 2 w. Same as 1R20 -----	99126-82	44211
1R25	Resistor: fixed, composition, 120,000 ohm $\pm 5\%$ , 2 w -----	99126-87	522412
1R26, 1R27	Resistor: fixed, composition, 470,000 ohm $\pm 5\%$ , 1 w -----	90496-94	512447
1R28, 1R29	Resistor: fixed, composition, 47 ohm $\pm 5\%$ , 2 w. Same as 1R1 -----	99126-5	522047
1R30	Resistor: fixed, composition, 82,000 ohm $\pm 5\%$ , 2 w -----	99126-205	522382
1R31	Resistor: 47,000 ohm $\pm 5\%$ , 2 w. Same as 1R20 -----	99126-82	44211
1R32, 1R33	Resistor: fixed, wire wound, 10,000 ohm $\pm 5\%$ , 10 w -----	458574-70	52077
1R34	Resistor: 47,000 ohm $\pm 5\%$ , 2 w. Same as 1R20 -----	99126-82	44211
1R35	Resistor: fixed, composition, 82,000 ohm $\pm 5\%$ , 2 w. Same as 1R30 --	99126-205	522382
1R36, 1R37	Resistor: fixed, composition, 47 ohm $\pm 5\%$ , 2 w. Same as 1R1 -----	99126-5	522047
1R38 to 1R41	Resistor: deposited carbon, 2.2 meg $\pm 5\%$ , 2 w -----	891769-1	18006
1R42, 1R43	Resistor: fixed, composition, 56,000 ohm $\pm 5\%$ , 2 w -----	99126-201	28741
1R44 to 1R47	Resistor: deposited carbon, 2.2 meg $\pm 5\%$ , 2 w. Same as 1R38 -----	891769-1	18006
1R48, 1R49	Not Used		
1R50	Resistor: variable, 15 ohm, 150 w -----	415724-4	51987
1R51	Resistor: fixed, wire wound, 1000 ohm $\pm 5\%$ , 10 w -----	458574-47	48568
1R52	Resistor: fixed, composition, 100 ohm $\pm 5\%$ , 10 w -----	458574-20	95878
1R53	Resistor: fixed, wire wound, 2500 ohm $\pm 2\%$ , 10 w -----	428781-6	44961
1R54, 1R55	Resistor: variable, 15,000 ohm $\pm 10\%$ , 3 w -----	737809-4	94940
1R56	Resistor: fixed, wire wound, 47 ohm $\pm 1\%$ , 1 w -----	8871557-20	95743
1R57	Resistor: fixed, wire wound, 240 ohm $\pm 1\%$ , 1 w -----	8871557-7	95551
1R58, 1R59	Resistor: fixed, wire wound, 17.2 ohm $\pm 1\%$ , 1 w -----	8871557-19	94943
1R60	Resistor: fixed, wire wound, 11.5 ohm $\pm 1\%$ , 1 w -----	8871557-15	93644
1R61, 1R62	Resistor: fixed, wire wound, 4.9 ohm $\pm 1\%$ , 2 w -----	8871557-17	94944

For ordering information see page 42.

SYMBOL NO.	DESCRIPTION	DRAWING NO.	STOCK NO.
1R63	Resistor: fixed, wire wound, 2500 ohm $\pm 1\%$ , 1 w -----	8871557-9	93646
1R64, 1R65	Resistor: fixed, wire wound, 400 ohm $\pm 1\%$ , 1 w -----	8871557-24	94945
1R66, 1R67	Resistor: fixed, wire wound, 68 ohm $\pm 1\%$ , 1 w -----	8871557-23	95024
1R68, 1R69	Resistor: fixed, wire wound, 5.7 ohm $\pm 1\%$ , 1 w -----	8871557-25	94946
1R70, 1R71	See Power-Determining Parts.		
1R72	Resistor: fixed, composition, 3900 ohm $\pm 10\%$ , 2 w -----	99126-69	48964
1R73	Resistor: fixed, wire wound, 20 ohm $\pm 5\%$ , 10 w -----	458574-4	95880
1S1	Switch: circuit breaker, filament, 6 amp., 230 v. ac, 50/60 cycle -----	445089-13	94159
1S2	Switch: circuit breaker, plate, 20 amp., 230 v. ac, 50/60 cycle -----	445089-22	94160
1S3, 1S4	Not Used		
1S5	Switch: circuit breaker, low power overload, 230 v -----	849370-6	94162
1S6	Switch: circuit breaker, PA cathode overload, 230 v -----	849370-5	94161
1S7	Switch: selector, 14 position, 2 pole with stop, non-shorting -----	459422-1	94413
1S8	Switch: circuit breaker, PA cathode overload, 230 v. Same as 1S6 -----	849370-5	94161
1S9, 1S10	Switch: grounding -----	481725-501	
	Insulator (2 used) (stationary) -----	426772-3	211370
	Insulator (moving) -----	426766-6	211371
	Contacts (2 used) (stationary) -----	8888796-1	211369
	Contact (moving) -----	8886452-3	211368
1S11	Switch: power change -----	8835558-1	94508
1S12	Switch: lights -----	8835558-1	94508
1S13, 1S14	Switch: interlock -----	8881052-1	54920
1S15	Switch: blower -----	8836936-1	94357
1S16	Switch: air flow -----	8820721-1	95686
1T1	Transformer: neutralizing -----	448083-501	93935
1T2	Transformer: r-f mod, monitoring -----	737585-501	93662
1T3	Transformer: a-f input -----	949347-1	93800
1T4	See Power-Determining Parts.		
1T5	Transformer: LV rectifier filament -----	450221-1	94358
1T6	Transformer: LV rectifier plate -----	949383-1	94411
1T7	Transformer: filament, 6.3 v -----	449383-1	94359
1T8, 1T9	Transformer: PA filament and mod., filament, 10 v -----	450218-1	94360
1T10	Transformer: HV rectifier filament -----	949325-1	93810
1T11	See Power-Determining Parts.		
1TC1	Thermocouple -----	8886911-1	
1XF1 to 1XF4	Holder: fuse -----	867236-1	19334
1XI1 to 1XI4	Not Used		
1XI5A, 1XI5B	Holder: lamp, lumiline -----	885233-1	45944
1XI5C, 1XI5D	Cap: lamp, lumiline -----	885234-1	45945
1XI6A, 1XI6B	Holder: lamp, lumiline. Same as 1XI5A -----	885233-1	45944
1XI6C, 1XI6D	Cap: lamp, lumiline. Same as 1XI5C -----	885234-1	45945
1XV1, 1XV2	Socket: buffer, RCA 807 -----	843314-2	9920
1XV3, 1XV4	Socket: PA, RCA 833A -----	737856-501	96757
1XV5 to 1XV8	Socket: buffer, RCA 807. Same as 1XV1 -----	843314-2	9920
1XV9, 1XV10	Socket: PA, RCA 833A. Same as 1XV3 -----	737856-501	96757
1XV11, 1XV12	Socket: LV rectifier, RCA 866A/866 -----	842821-1	9937
1XV13, 1XV14	Socket: HV rectifier, RCA 8008 -----	429151-1	9917
1XY1	Socket: spare crystal -----	835375-501	55336
1Y1	Crystal Unit -----	MI-7467	
1Y2	Crystal Oscillator Unit (See Preceding List.) -----	MI-19458	
1Z1, 1Z2	Feedback Ladder-Board Assembly: -----	459492-501	
	Capacitor: fixed, mica, 510 mmf $\pm 5\%$ , 2500 v -----	728647-234	94164
	Capacitor: fixed, mica, 18,000 mmf $\pm 5\%$ , 600 v -----	728647-271	94165
	Resistor: deposited carbon, 2.2 meg $\pm 5\%$ , 2 w -----	891769-1	18006
	Resistor: fixed, composition, 68,000 ohm $\pm 5\%$ , 2 w -----	99126-203	522368
1Z3	See Power-Determining Parts (BTA-500MX).		
MISCELLANEOUS			
	Clip: resistor, for 13/16 dia. ferrule -----	838400-2	42736
	Clip: resistor, for 1-1/16 dia. ferrule -----	7862770-1	52717
	Connector: tube cap, RCA 833A -----	8835526-1	94155
	Connector: tube cap, RCA 866A -----	8890121-503	94327
	Connector: tube cap, RCA 807, 866 -----	8890120-501	94393
	Connector: tube cap, RCA 8008 -----	8890121-504	94327
	Control: 70-tooth gear for No. 1 cable -----	8898735-2	95213

For ordering information see page 42.

SYMBOL NO.	DESCRIPTION	DRAWING NO.	STOCK NO.
	Coupling: flexible, for 1S7 control ----- Joint: universal, for 1R50 control ----- Knob: control (for 1R50, 1S7, 1R71) ----- Shield: tube shield assembly, (RCA 807) -----	838103-3 860847-2 712336-501 875609-501	95883 47190 17269 47299
<b>BTA-500MX, FREQUENCY-DETERMINING PARTS, MI-27093</b>			
	<u>MI-27093-1, 535-650 KC, 51.5 Ohm line</u>		
1C21 1C23, 1C24	Capacitor: fixed, mica, 330 mmf $\pm 5\%$ , 10,000 v ----- Capacitor: fixed, mica, 15,000 mmf $\pm 5\%$ , 4000 v -----	32228-601 32229-641	211957 213479
	<u>MI-27093-2, 535-650 KC, 75 Ohm line</u>		
1C21 1C23 1C24	Capacitor: fixed, mica, 330 mmf $\pm 5\%$ , 10,000 v ----- Capacitor: fixed, mica, 10,000 mmf $\pm 5\%$ , 5000 v ----- Capacitor: fixed, mica, 12,000 mmf $\pm 5\%$ , 4000 v -----	32228-601 32229-621 32229-631	211957 96181 213478
	<u>MI-27093-3, 535-650 KC, 230 Ohm line</u>		
1C21 1C23 1C24	Capacitor: fixed, mica, 330 mmf $\pm 5\%$ , 10,000 v ----- Capacitor: fixed, mica, 3000 mmf $\pm 5\%$ , 8000 v ----- Capacitor: fixed, mica, 3900 mmf $\pm 5\%$ , 8000 v -----	32228-601 32229-556 32229-571	211957 95407 96178
	<u>MI-27093-4, 650-780 KC, 51.5 Ohm line</u>		
1C21 1C23, 1C24	Capacitor: fixed, mica, 100 mmf $\pm 5\%$ , 10,000 v ----- Capacitor: fixed, mica, 12,000 mmf $\pm 5\%$ , 4000 v -----	32228-541 32229-631	211956 213478
	<u>MI-27093-5, 650-780 KC, 72 Ohm line</u>		
1C21 1C23 1C24	Capacitor: fixed, mica, 100 mmf $\pm 5\%$ , 10,000 v ----- Capacitor: fixed, mica, 8200 mmf $\pm 5\%$ , 5000 v ----- Capacitor: fixed, mica, 10,000 mmf $\pm 5\%$ , 5000 v -----	32228-541 32229-611 32229-621	211956 96180 96181
	<u>MI-27093-6, 650-780 KC, 230 Ohm line</u>		
1C21 1C23, 1C24	Capacitor: fixed, mica, 100 mmf $\pm 5\%$ , 10,000 v ----- Capacitor: fixed, mica, 3000 mmf $\pm 5\%$ , 8000 v -----	32228-541 32229-556	211956 95407
	<u>MI-27093-7, 780-940 KC, 51.5 Ohm line</u>		
1C21 1C23, 1C24	Capacitor: fixed, mica, 56 mmf $\pm 5\%$ , 10,000 v ----- Capacitor: fixed, mica, 10,000 mmf $\pm 5\%$ , 5000 v -----	32228-511 32229-621	213477 96181
	<u>MI-27093-8, 780-940 KC, 72 Ohm line</u>		
1C21 1C23 1C24	Capacitor: fixed, mica, 56 mmf $\pm 5\%$ , 10,000 v ----- Capacitor: fixed, mica, 6200 mmf $\pm 5\%$ , 5000 v ----- Capacitor: fixed, mica, 8200 mmf $\pm 5\%$ , 5000 v -----	32228-511 32229-596 32229-611	213477 96179 96180
	<u>MI-27093-9, 780-940 KC, 230 Ohm line</u>		
1C21 1C23 1C24	Capacitor: fixed, mica, 56 mmf $\pm 5\%$ , 10,000 v ----- Capacitor: fixed, mica, 2000 mmf $\pm 5\%$ , 10,000 v ----- Capacitor: fixed, mica, 3000 mmf $\pm 5\%$ , 8000 v -----	32228-511 32229-536 32229-556	213477 96177 95407

For ordering information see page 42.

SYMBOL NO.	DESCRIPTION	DRAWING NO.	STOCK NO.
	<u>MI-27093-10, 940-1120 KC, 51.5 Ohm line</u>		
1C23	Capacitor: fixed, mica, 8200 mmf $\pm 5\%$ , 5000 v -----	32229-611	96180
1C24	Capacitor: fixed, mica, 10,000 mmf $\pm 5\%$ , 5000 v -----	32229-621	96181
	<u>MI-27093-11, 940-1120 KC, 72 Ohm line</u>		
1C23, 1C24	Capacitor: fixed, mica, 6200 mmf $\pm 5\%$ , 5000 v -----	32229-596	96179
	<u>MI-27093-12, 940-1120 KC, 230 Ohm line</u>		
1C23, 1C24	Capacitor: fixed, mica, 2000 mmf $\pm 5\%$ , 10,000 v -----	32229-536	96177
	<u>MI-27093-13, 1120-1340 KC, 51.5 Ohm line</u>		
1C23	Capacitor: fixed, mica, 6200 mmf $\pm 5\%$ , 5000 v -----	32229-596	96179
1C24	Capacitor: fixed, mica, 8200 mmf $\pm 5\%$ , 5000 v -----	32229-611	96180
	<u>MI-27093-14, 1120-1340 KC, 72 Ohm line</u>		
1C23	Capacitor: fixed, mica, 3900 mmf $\pm 5\%$ , 8000 v -----	32229-571	96178
1C24	Capacitor: fixed, mica 6200 mmf $\pm 5\%$ , 5000 v -----	32229-596	96179
	<u>MI-27093-15, 1120-1340 KC, 230 Ohm line</u>		
1C23	Capacitor: fixed, mica, 1500 mmf $\pm 5\%$ , 10,000 v -----	32229-521	96176
1C24	Capacitor: fixed, mica, 2000 mmf $\pm 5\%$ , 10,000 v -----	32229-536	96177
	<u>MI-27093-16, 1340-1620 KC, 51.5 Ohm line</u>		
1C23, 1C24	Capacitor: fixed, mica, 6200 mmf $\pm 5\%$ , 5000 v -----	32229-596	96179
	<u>MI-27093-17, 1340-1620 KC, 72 Ohm line</u>		
1C23	Capacitor: fixed, mica, 3000 mmf $\pm 5\%$ , 8000 v -----	32229-556	95407
1C24	Capacitor: fixed, mica, 6200 mmf $\pm 5\%$ , 5000 v -----	32229-596	96179
	<u>MI-27093-18, 1340-1620 KC, 230 Ohm line</u>		
1C23, 1C24	Capacitor: fixed, mica, 1500 mmf $\pm 5\%$ , 10,000 v -----	32229-521	96176
<b>BTA-1MX, FREQUENCY-DETERMINING PARTS, MI-28096A</b>			
	<u>MI-28096A-1, 535-650 KC, 51.5 Ohm line</u>		
1C21, 1C22	Capacitor: fixed, mica, 1300 mmf $\pm 5\%$ , 10,000 v -----	32229-516	96175
1C23, 1C24	Capacitor: fixed, mica, 10,000 mmf $\pm 5\%$ , 5000 v -----	32229-621	96181
	<u>MI-28096A-2, 535-650 KC, 72 Ohm line</u>		
1C21, 1C22	Capacitor: fixed, mica, 1300 mmf $\pm 5\%$ , 10,000 v -----	32229-516	96175
1C23, 1C24	Capacitor: fixed, mica, 10,000 mmf $\pm 5\%$ , 5000 v -----	32229-621	96181

For ordering information see page 42.

SYMBOL NO.	DESCRIPTION	DRAWING NO.	STOCK NO.
<u>MI-28096A-3, 535-650 KC, 230 Ohm line</u>			
1C21, 1C22	Capacitor: fixed, mica, 1300 mmf $\pm 5\%$ , 10,000 v -----	32229-516	96175
1C23	Capacitor: fixed, mica, 3900 mmf $\pm 5\%$ , 8000 v -----	32229-571	96178
1C24	Capacitor: fixed, mica, 3000 mmf $\pm 5\%$ , 8000 v -----	32229-556	95407
<u>MI-28096A-4, 650-780 KC, 51.5 Ohm line</u>			
1C21	Capacitor: fixed, mica, 620 mmf $\pm 5\%$ , 10,000 v -----	32228-636	96173
1C22	Capacitor: fixed, mica, 1000 mmf $\pm 5\%$ , 10,000 v -----	32229-501	96174
1C23, 1C24	Capacitor: fixed, mica, 8200 mmf $\pm 5\%$ , 5000 v -----	32229-611	96180
<u>MI-28096A-5, 650-780 KC, 72 Ohm line</u>			
1C21	Capacitor: fixed, mica, 620 mmf $\pm 5\%$ , 10,000 v -----	32228-636	96173
1C22	Capacitor: fixed, mica, 1000 mmf $\pm 5\%$ , 10,000 v -----	32229-501	96174
1C23, 1C24	Capacitor: fixed, mica, 8200 mmf $\pm 5\%$ , 5000 v -----	32229-611	96180
<u>MI-28096A-6, 650-780 KC, 230 Ohm line</u>			
1C21	Capacitor: fixed, mica, 620 mmf $\pm 5\%$ , 10,000 v -----	32228-636	96173
1C22	Capacitor: fixed, mica, 1000 mmf $\pm 5\%$ , 10,000 v -----	32229-501	96174
1C23, 1C24	Capacitor: fixed, mica, 3000 mmf $\pm 5\%$ , 8000 v -----	32229-556	95407
<u>MI-28096A-7, 780-940 KC, 51.5 Ohm line</u>			
1C21	Capacitor: fixed, mica, 330 mmf $\pm 5\%$ , 10,000 v -----	32228-601	211957
1C23	Capacitor: fixed, mica, 8200 mmf $\pm 5\%$ , 5000 v -----	32229-611	96180
1C24	Capacitor: fixed, mica, 6200 mmf $\pm 5\%$ , 5000 v -----	32229-596	96179
<u>MI-28096A-8, 780-940 KC, 72 Ohm line</u>			
1C21	Capacitor: fixed, mica, 330 mmf $\pm 5\%$ , 10,000 v -----	32228-601	211957
1C23	Capacitor: fixed, mica, 8200 mmf $\pm 5\%$ , 5000 v -----	32229-611	96180
1C24	Capacitor: fixed, mica, 6200 mmf $\pm 5\%$ , 5000 v -----	32229-596	96179
<u>MI-28096A-9, 780-940 KC, 230 Ohm line</u>			
1C21	Capacitor: fixed, mica, 330 mmf $\pm 5\%$ , 10,000 v -----	32228-601	211957
1C23	Capacitor: fixed, mica, 3000 mmf $\pm 5\%$ , 8000 v -----	32229-556	95407
1C24	Capacitor: fixed, mica, 2000 mmf $\pm 5\%$ , 10,000 v -----	32229-536	96177
<u>MI-28096A-10, 940-1120 KC, 51.5 Ohm line</u>			
1C21	Capacitor: fixed, mica, 330 mmf $\pm 5\%$ , 10,000 v -----	32228-601	211957
1C23, 1C24	Capacitor: fixed, mica, 6200 mmf $\pm 5\%$ , 5000 v -----	32229-596	96179
<u>MI-28096A-11, 940-1120 KC, 72 Ohm line</u>			
1C21	Capacitor: fixed, mica, 330 mmf $\pm 5\%$ , 10,000 v -----	32228-601	211957
1C23, 1C24	Capacitor: fixed, mica, 6200 mmf $\pm 5\%$ , 5000 v -----	32229-596	96179
<u>MI-28096A-12, 940-1120 KC, 230 Ohm line</u>			
1C21	Capacitor: fixed, mica, 330 mmf $\pm 5\%$ , 10,000 v -----	32228-601	211957
1C23, 1C24	Capacitor: fixed, mica, 2000 mmf $\pm 5\%$ , 10,000 v -----	32229-536	96177

For ordering information see page 42.

SYMBOL NO.	DESCRIPTION	DRAWING NO.	STOCK NO.
<u>MI-28096A-13, 1120-1340 KC, 51.5 Ohm line</u>			
1C21	Capacitor: fixed, mica, 100 mmf $\pm 5\%$ , 10,000 v -----	32228-541	211956
1C23	Capacitor: fixed, mica, 6200 mmf $\pm 5\%$ , 5000 v -----	32229-596	96179
1C24	Capacitor: fixed, mica, 3900 mmf $\pm 5\%$ , 8000 v -----	32229-571	96178
<u>MI-28096A-14, 1120-1340 KC, 72 Ohm line</u>			
1C21	Capacitor: fixed, mica, 100 mmf $\pm 5\%$ , 10,000 v -----	32228-541	211956
1C23, 1C24	Capacitor: fixed, mica, 3900 mmf $\pm 5\%$ , 8000 v -----	32229-571	96178
<u>MI-28096A-15, 1120-1340 KC, 230 Ohm line</u>			
1C21	Capacitor: fixed, mica, 100 mmf $\pm 5\%$ , 10,000 v -----	32228-541	211956
1C23, 1C24	Capacitor: fixed, mica, 1500 mmf $\pm 5\%$ , 10,000 v -----	32229-521	96176
1C25	Capacitor: fixed, mica, 510 mmf $\pm 5\%$ , 10,000 v -----	32228-626	94881
<u>MI-28096A-16, 1340-1620 KC, 51.5 Ohm line</u>			
1C21	Capacitor: fixed, mica, 100 mmf $\pm 5\%$ , 10,000 v -----	32228-541	211956
1C23, 1C24	Capacitor: fixed, mica, 3900 mmf $\pm 5\%$ , 8000 v -----	32229-571	96178
<u>MI-28096A-17, 1340-1620 KC, 72 Ohm line</u>			
1C21	Capacitor: fixed, mica, 100 mmf $\pm 5\%$ , 10,000 v -----	32228-541	211956
1C23, 1C24	Capacitor: fixed, mica, 3000 mmf $\pm 5\%$ , 8000 v -----	32229-556	95407
<u>MI-28096A-18, 1340-1620 KC, 230 Ohm line</u>			
1C21	Capacitor: fixed, mica, 100 mmf $\pm 5\%$ , 10,000 v -----	32228-541	211956
1C23 to 1C25	Capacitor: fixed, mica, 1000 mmf $\pm 5\%$ , 10,000 v -----	32229-501	96174
<b>BTA-500MX, POWER-DETERMINING PARTS, MI-27092-A</b>			
1C20	Capacitor: fixed, mica, 62 mmf $\pm 5\%$ , 2500 v -----	728647-212	208204
1C51	Capacitor: fixed, paper, 1 mf $\pm 10\%$ , 6000 v -----	990193-164	208205
1L13	Reactor: H. V. filter -----	900303-1	95657
1L14	Reactor: modulation, 70 henry, 300 ma -----	949858-1	208206
1M3	Meter: 0-500 ma, dc -----	482744-3	211714
1R10	Resistor: fixed, wire wound, 1600 ohm $\pm 10\%$ , 45 w -----	99029-33	52076
1R19	Resistor: fixed, composition, 150,000 ohm $\pm 10\%$ , 2 w -----	99126-88	522415
1R70	Resistor: fixed, wire wound, 50 ohm $\pm 5\%$ , 10 w -----	458574-12	208207
1R71	Resistor: variable -----	433464-17	208409
1R72	Resistor: fixed, composition, 5600 ohm $\pm 10\%$ , 2 w -----	99126-71	522256
1T4	Transformer: audio -----	949857-1	208209
1T11	Transformer: plate -----	949864-1	213308
1Z3	Equalizer: -----	755773-501	
	3C1 - Capacitor: fixed, paper, 0.068 mf $\pm 10\%$ , 200 v -----	990417-124	210803
	3C2 - Capacitor: fixed, mica, 330 mmf $\pm 5\%$ , 300 v -----	722031-513	99630
	3L1 - Choke: R. F. -----	862943-12	210804
	3L2 - Choke: R. F. -----	8913168-1	210805
	3R1, 3R2 - Resistor: fixed, composition, 390 ohm $\pm 10\%$ , 1/2 w ---	722320-57	30498
	3R3 to 3R6 - Resistor: fixed, composition, 1200 ohm $\pm 10\%$ , 1/2 w	722320-63	502212
	3R7 - Resistor: fixed, composition, 1800 ohm $\pm 10\%$ , 1/2 w -----	722320-65	502218



For ordering information see page 42.

SYMBOL NO.	DESCRIPTION	DRAWING NO.	STOCK NO.
<b>BTA-1MX, POWER-DETERMINING PARTS, MI-27091-A</b>			
1C13, 1C14	Capacitor: fixed, mica, 3300 mmf $\pm 20\%$ , 2500 v -----	728647-53	94171
1C20	Capacitor: fixed, mica, 120 mmf $\pm 10\%$ , 2500 v -----	728647-119	94935
1C51	Capacitor: fixed, paper, 2 mf $\pm 10\%$ , 6000 v -----	990193-165	94168
1L13	Reactor: H. V. filter -----	900304-1	52038
1L14	Reactor: modulation, 50 henry -----	900289-1	208210
1M3	Meter: 0-1 amp, dc -----	482744-4	211715
1R10	Resistor: fixed, wire wound, 1000 ohm $\pm 10\%$ , 45 w -----	99029-31	50706
1R70	Resistor: fixed, composition, 25 ohm $\pm 5\%$ , 10 w -----	458574-5	210528
1R71	Resistor: variable, 400 ohm, 150 w -----	415724-10	213254
1T4	Transformer: modulation -----	450217-1	94404
1T11	Transformer: H. V. plate -----	949285-1	94412
<b>MISCELLANEOUS</b>			
	Connector: PA plate and grid -----	8835526-1	94155
<b>POWER-CHANGE KIT; 1000/500/250 WATTS, 500/250 WATTS; MI-28099</b>			
2C1	Capacitor: fixed, mica, 2000 mmf $\pm 5\%$ , 500 v -----	32222-574	553054
2K1	Relay: D. P. D. T., 220 v. ac, 50/60 cycle -----	8836923-1	94949
2R1 to 2R6	Resistor: fixed, wire wound, 700 ohm $\pm 10\%$ , 150 w -----	883809-3	17327
2R7	Resistor: fixed, wire wound, 600 ohm $\pm 10\%$ , 150 w -----	883809-2	17326
2R8	Resistor: tapped, 450 ohm total, 9 taps, 10 equal resistances -----	890014-10	17282
<b>MISCELLANEOUS</b>			
	Clip: resistor, for 1-1/16" dia. ferrule -----	7862770-1	52717
	Insulator: steatite, square post, 3/4" #10-32 tap both ends -----	426773-5	92430
<b>60 to 50-CYCLE CONVERSION KIT, MI-28098</b>			
	Motor: 50 cycle -----	744420-5	

RECOMMENDED STATION SPARES (BTA-500MX/1MX)

For ordering information see page 42.

SYMBOL NO.	DESCRIPTION	QTY.	DRAWING NO.	STOCK NO.
1C1 to 1C3, 1C8, 1C9, 1C61	Capacitor: fixed, mica, 0.01 mf $\pm 20\%$ , 1200 v -----	1	728647-65	610003
1C4	Capacitor: fixed, mica, 1000 mf $\pm 20\%$ , 2500 v -----	1	728647-41	601002
1C5, 1C6	Capacitor: fixed, mica, 620 mmf $\pm 5\%$ , 3500 v -----	1	8843560-7	93930
1C7	Capacitor: fixed, mica, 4700 mmf $\pm 10\%$ , 1200 v -----	1	728647-157	95215
1C11, 1C12	Capacitor: fixed, mica, 3300 mmf $\pm 20\%$ , 2500 v -----	1	728647-53	94171
1C15	Capacitor: fixed, mica, 510 mmf $\pm 5\%$ , 10,000 v -----	1	32228-627	94881
1C16	Capacitor: fixed, ceramic, 200 mmf, 10,000 v -----	1	8889035-1	94172
1C17	Capacitor: fixed, mica, 2000 mmf $\pm 5\%$ , 5000 v -----	1	32222-574	553054
1C18	Capacitor: fixed, mica, 300 mf $\pm 5\%$ , 5000 v -----	1	32221-532	553109
1C33, 1C37, 1C38	Capacitor: fixed, paper, 1.0 mf $\pm 10\%$ , 600 v -----	1	984688-8	56124
1C35, 1C36	Capacitor: fixed, paper, 0.25 mf $\pm 10\%$ , 1000 v -----	1	984643-26	95214
1C39 to 1C42, 1C45 to 1C48	Capacitor: fixed, mica, 510 mmf $\pm 5\%$ , 2500 v -----	2	728647-234	94164
1C43, 1C44	Capacitor: fixed, mica, 18,000 mmf $\pm 5\%$ , 600 v -----	1	728647-271	94165
1C53, 1C54	Capacitor: fixed, oil, 10 mf, 400 v -----	1	450184-4	57017
1C55	Capacitor: fixed, paper, 15.0 mf $\pm 10\%$ , 600 v -----	1	990193-10	208749
1C58, 1C59	Capacitor: fixed, paper, 6.0 mf $\pm 10\%$ , 3000 v -----	1	990193-107	95788
1F1, 1F2	Fuse: crystal heater, 1 amp -----	3	850339-6	19335
1F3, 1F4	Fuse: cabinet light, 2 amp -----	3	850339-8	45532
1I1 to 1I4	Lamp: indicator (lamp only) -----	2	459610-36	16154
1I5, 1I6	Lamp: lumiline interior, 115 v., ac -----	2	885232-2	93916
1K1	Relay: plate time delay coil, 220 v., 50/60 cycle, 1 contact normally open -----	1	429587-1	44549
1K2	Contact: plate -----		8832129-3	94361
	Coil -----	1	8832129-29	205263
	Contact - movable -----	2	8832129-32	205267
	Contact - stationary, rear -----	2	8832129-35	205265
	Contact - stationary, front -----	2	8832129-36	205266
1L4	Coil: PA grid -----	1	412784-501	16892
1L5	Coil: PA plate -----	1	418486-501	19185
1L15	Reactor: buffer plate -----	1	884432-3	95881
1R16	Resistor: osc. volt divider, fixed, wire wound, 6300 ohm, 45 watt -----	1	99029-39	94752
1R38 to 1R41, 1R44 to 1R47	Resistor: feedback, deposited carbon, 2.2 meg $\pm 5\%$ , 2 watt -----	2	891769-1	18006
1R42, 1R43	Resistor: feedback, fixed, composition, 56,000 ohm $\pm 5\%$ , 2 watt -----	1	99126-201	28741
1S1	Switch: circuit breaker, filament, 6 amps, 230 v. ac, 50/60 cycle -----	1	445089-13	94159
1S2	Switch: circuit breaker, plate, 20 amp, 230 v. ac, 50/60 cycle -----	1	445089-22	94160
1S5	Switch: circuit breaker, low power overload, 230 v -----	1	849370-6	94162
1S6, 1S8	Switch: circuit breaker, PA cathode overload, 230 v -----	1	849370-5	94161
1S13, 1S14	Switch: interlock -----	1	8881052-1	54920
1S15	Switch: blower -----	1	8836936-1	94357
1T1	Transformer: neutralizing -----	1	448083-501	93935

INSULATOR DATA

For ordering information see page 42.

MOUNTING FOR OR MOUNTED NEAR	FIGURE	DIMENSIONS (inches)					TAP SIZE	RCA DRAWING NO.	STOCK NO.
		A	B	C	D	E			
1R10, 1R13, 1R26, 1R48, 1R49	A	1-1/4	3/4	-	-	-	10-32	426773-5	92430
1Z1, 1Z2	B	1-1/2	1/2	1	-	-	8-32	426762-5	51 781
1C35, 1C36	D	1-1/4	1/2	-	-	-	8-32	426766-12	53348
1TC1	C	1-1/8	7/8	1-3/4	1-3/4	-	-	426761-10	51088
1C5, 1C6, 1C9, 1C20, 1C37, 1C38	D	1/2	3/8	-	-	-	6-32	426765-2	92075
1C30	D	1	3/8	-	-	-	6-32	426765-11	92010
1TC1	D	3/4	1/2	-	-	-	8-32	426766-5	52681
1C37, 1L4, 1R55, 1XV2, 1XV7, 1XV8	D	1-1/2	1/2	-	-	-	8-32	426766-14	52128
1C37, 1C38	D	2	1/2	-	-	-	8-32	426766-17	55918
1M4, 1R50	D	1	3/4	-	-	-	10-32	426767-2	51086
1C16, 1C51	D	1-1/2	3/4	-	-	-	10-32	426767-8	51087
1S9, 1S10:									
Stationary	A	3/4	1/2	-	-	-	8-32	426772-3	211370
Moving	D	3/4	1/2	-	-	-	8-32	426766-6	211371
1C15	D	1-1/2	1	-	-	-	1/4-20	426768-5	55800
1XV1, 1XV2, 1XV5, 1XV6, 1XV7, 1XV8	G	5/8	1/2	5/8	23/64	5/32	-	426764-5	52111
1XV1, 1XV2, 1XV5, 1XV6, 1XV7, 1XV8	H	3/8	1/2	5/8	3/8	5/32	-	426764-55	51517
1XV11 to 1XV14	G	7/8	3/4	7/8	31/64	13/64	-	426764-8	51783
1XV11 to 1XV14	H	1/2	3/4	7/8	1/2	13/64	-	426764-58	51784
1XV3, 1XV4, 1XV9, 1XV10									
Includes 2 parts:									
Part A	G	1-5/16	1	1-1/8	47/64	0.2	-	426764-12 )	210340
Part B	H	3/4	1	1-1/8	3/4	0.2	-	426764-62 )	

See Figure 10 for insulator details.

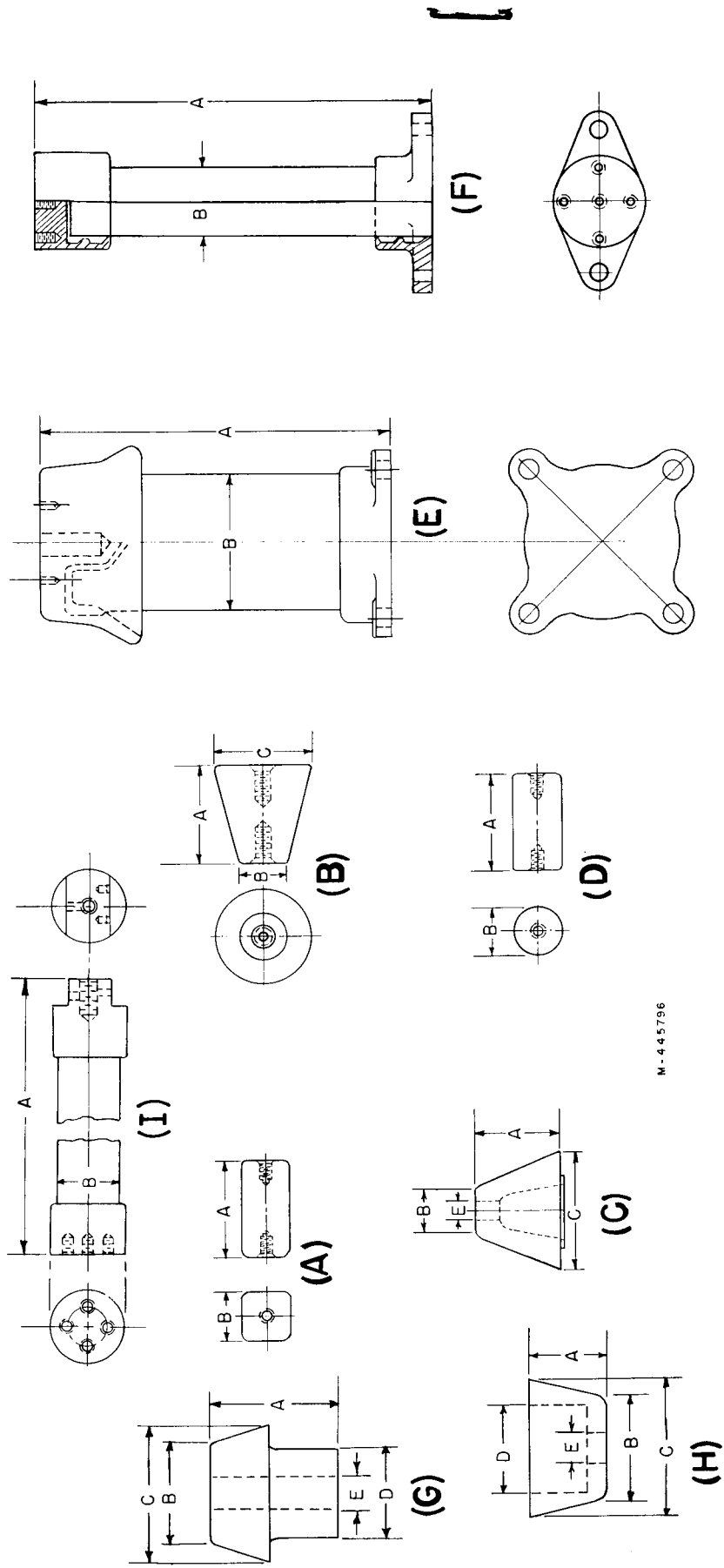

Figure 10. Insulator Details (445796 sub 3)

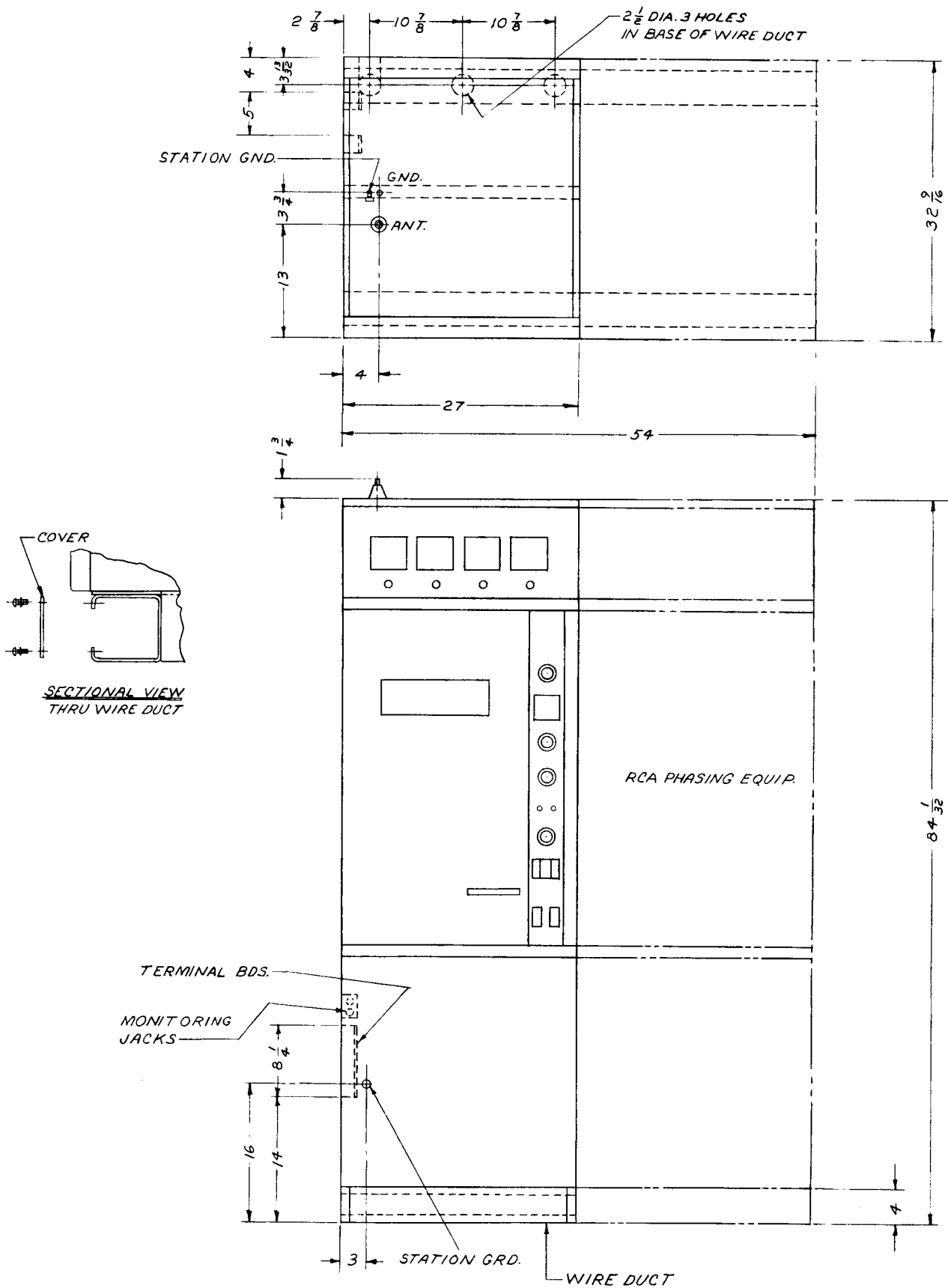
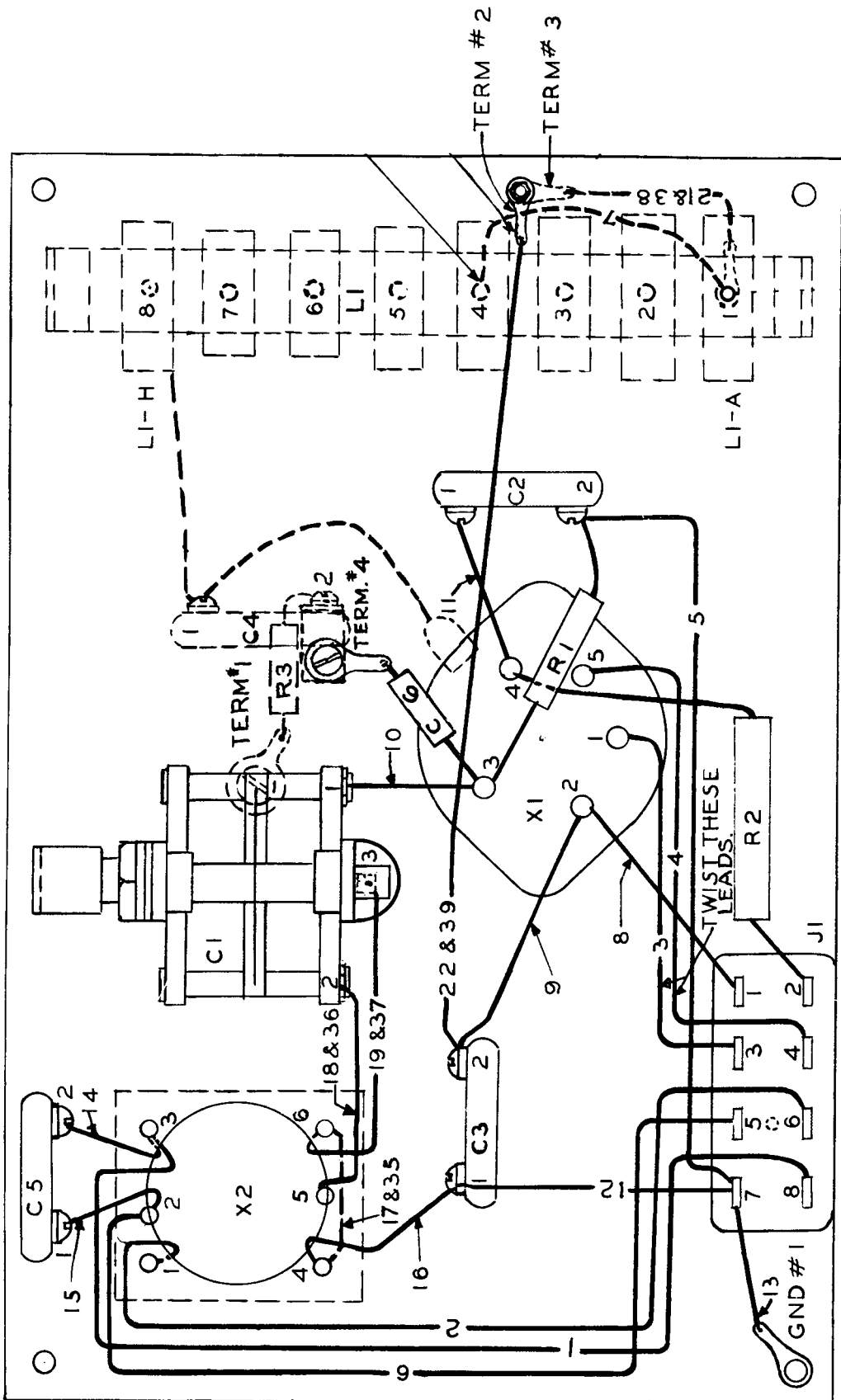

Figure 12. Outline, BTA-500MX or BTA-1MX Transmitter (8700160 sub 0)



BOTTOM VIEW  
(PANEL)

Figure 13. Connection Diagram, Oscillator (429907 sub 7)



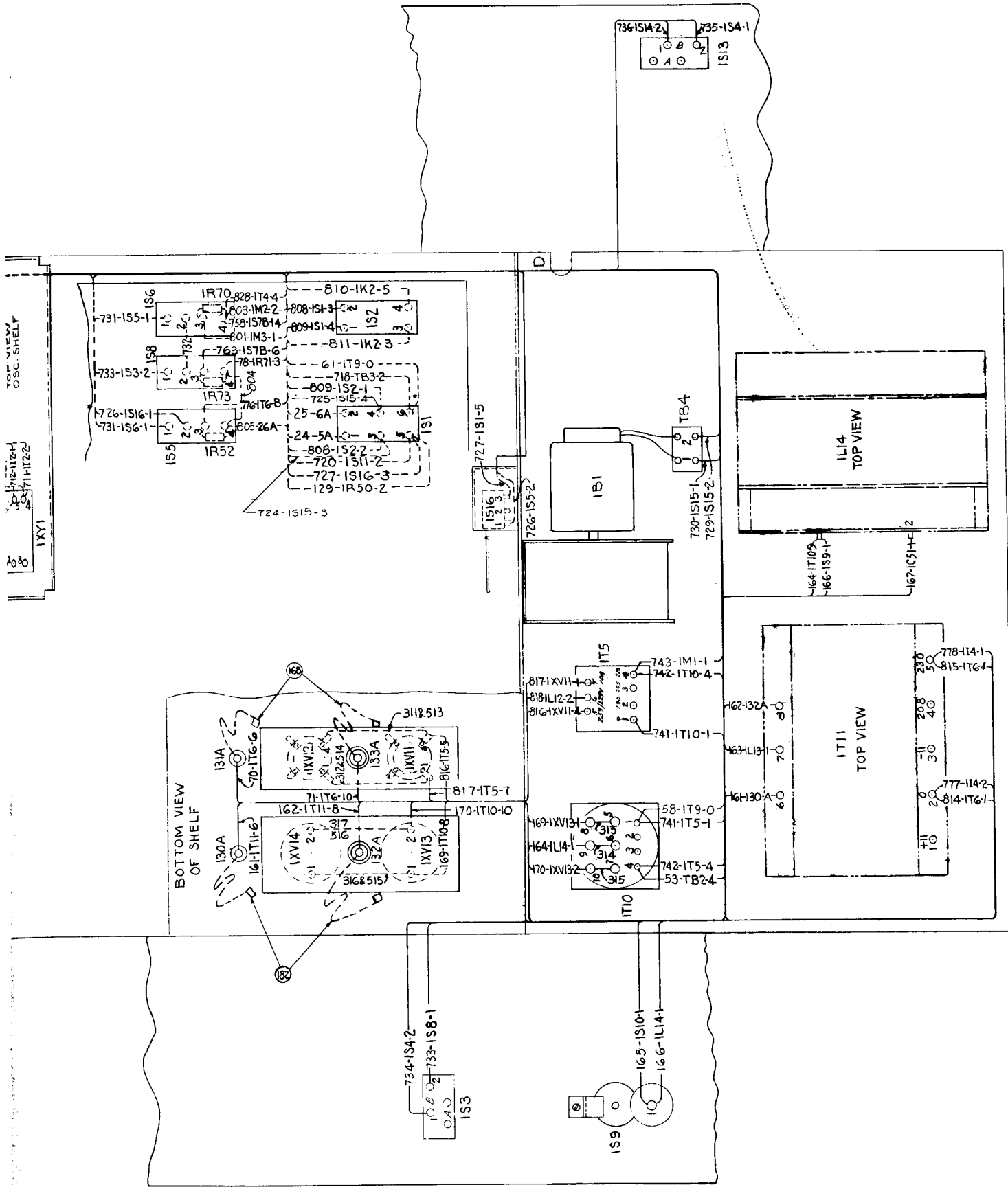

FRONT VIEW

100



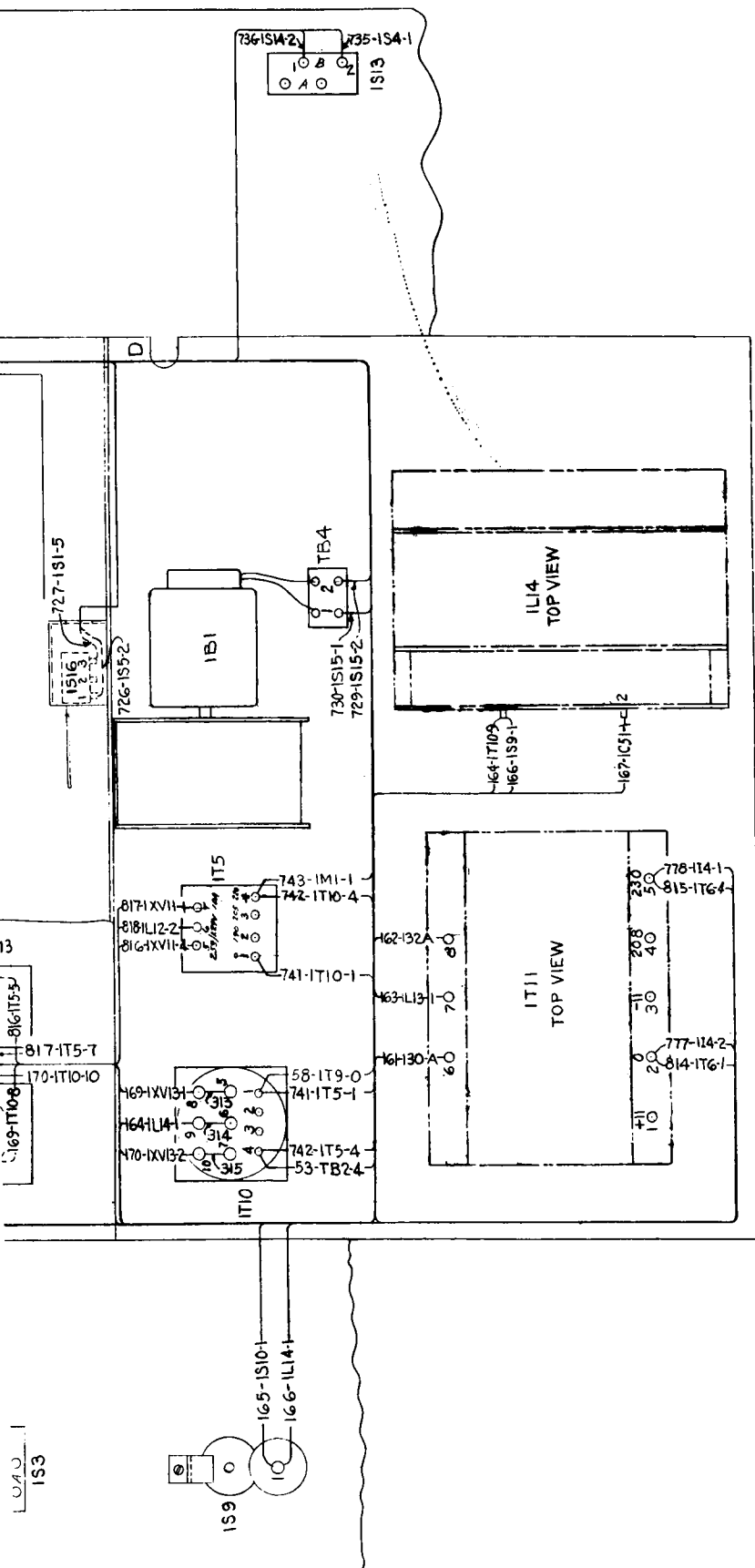

FRONT VIEW

WIRE TABLE		
WIRE NUMBER	DESCRIPTION	ITEM NO SEE A-8834251
14, 15, 18, 20, 23, 45, 53, 56, 58, 60, 61, 70, 71, 72, 124, 129, 131, 136	PS 724-32 65/010 BLK 2500 V.	169
151 TO 154 INCL 156, 158 TO 170 INCL	PS 728-14 600 V. 19/0185 BLK 10 K V.	170
210 & 212	K-832462-3 SHIELDED PAIR IRED 1BLK	171
221 TO 230 236 TO 245 247 TO 254 INCL	PS 105 .128 DIA TINNED COPPER WIRE	172
271 TO 326 INCL	PS 105 .0641 DIA TINNED COPPER WIRE	173
351 TO 365, 367 TO 372 INCL	PS 105 .0401 DIA TINNED COPPER WIRE	174
501 TO 516 INCL	PS 8 .066 I.D. TUBING BLK.	176
601 TO 604 INCL	PS 8 .053 I.D. TUBING BLK.	177
201 & 202	99253-2 CO-AX CABLE	196
701 TO 764 767 TO 782 INCL.	PS 724-20 26/010 BLK 600 V.	194
801 TO 805 & 808 TO 832 INCL.	PS 724-34 41/010 BLK 600 V.	193
901	K-838860-1 7X24X.005 FLEX LEAD	195
413 TO 424 INCL	A8816267-1 LINK	213
401	K-838860-1 7X24X.005 FLEX LEAD	215
402 & 409	K-838860-1 7X24X.005 FLEX LEAD	216
405	K-838860-1 7X24X.005 FLEX LEAD	217
404	K-838860-1 7X24X.005 FLEX LEAD	218
407	K-838860-1 7X24X.005 FLEX LEAD	219
406	K-838860-1 7X24X.005 FLEX LEAD	220
407	K-838860-1 7X24X.005 FLEX LEAD	221
408 & 408	K-838860-1 7X24X.005 FLEX LEAD	222
410	K-838860-1 7X24X.005 FLEX LEAD	223
411	K-838860-1 7X24X.005 FLEX LEAD	224
412	K-838860-1 7X24X.005 FLEX LEAD	225

NOTE 1- NUMBERS IN WIRES REFER TO TABLE AND DESTINATION RESPECTIVELY EG. 57-IT5-1 INDICATES WIRE 57 IS CONNECTED TO TERMINAL 1 ON IT5.

Figure 14. Connection Diagram, Transmitter Front (318834 sub 2)

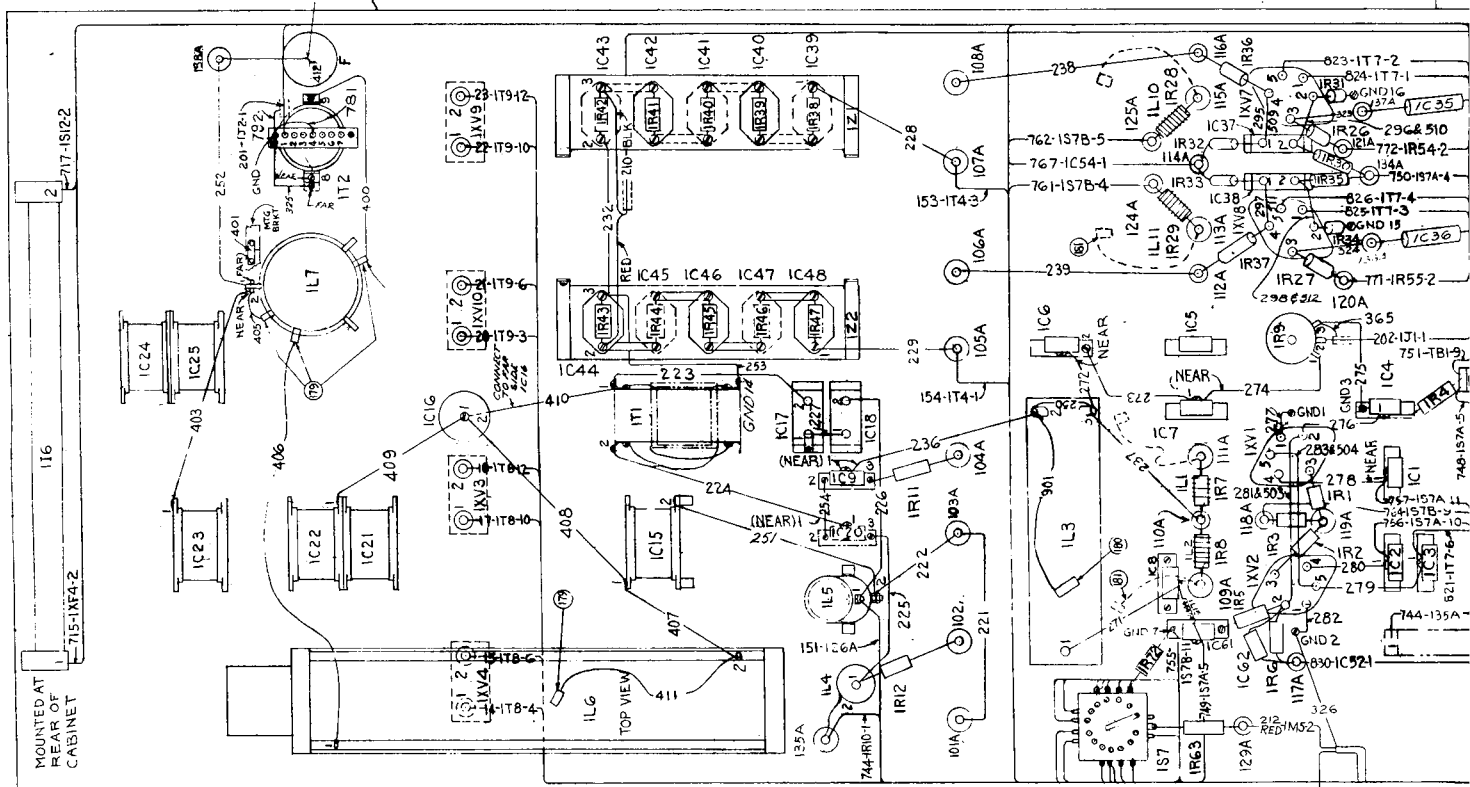

CONNECTIONS SHOWN FOR 1000/500 WATT OPERATION FOR 1000/250 WATT OPERATION OMIT 2R7 & CONNECT 2R1-2R2-2R3-2R4-2R5-2R6 & 2R8 IN SERIES REMOVE CONNECTOR BETWEEN 126A & 127A WHEN POWER CHANGE KIT IS USED

CONNECTIONS FOR OPTIONAL POWER CHANGE EQUIPMENT MI 28099 FOR 250/500/1000 WATTS OUTPUT

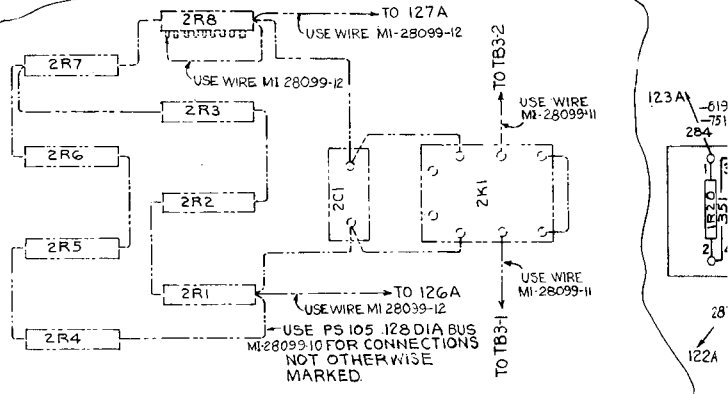

MOUNTED AT REAR OF CABINET  
 116  
 715-11K4-2  
 717-1S12-2

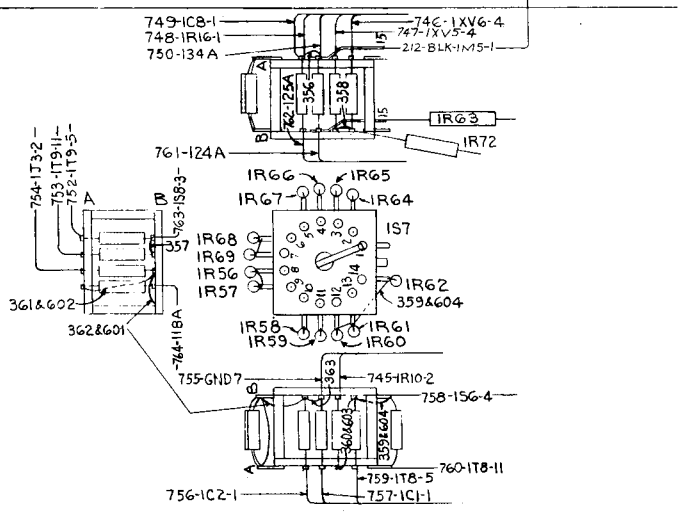



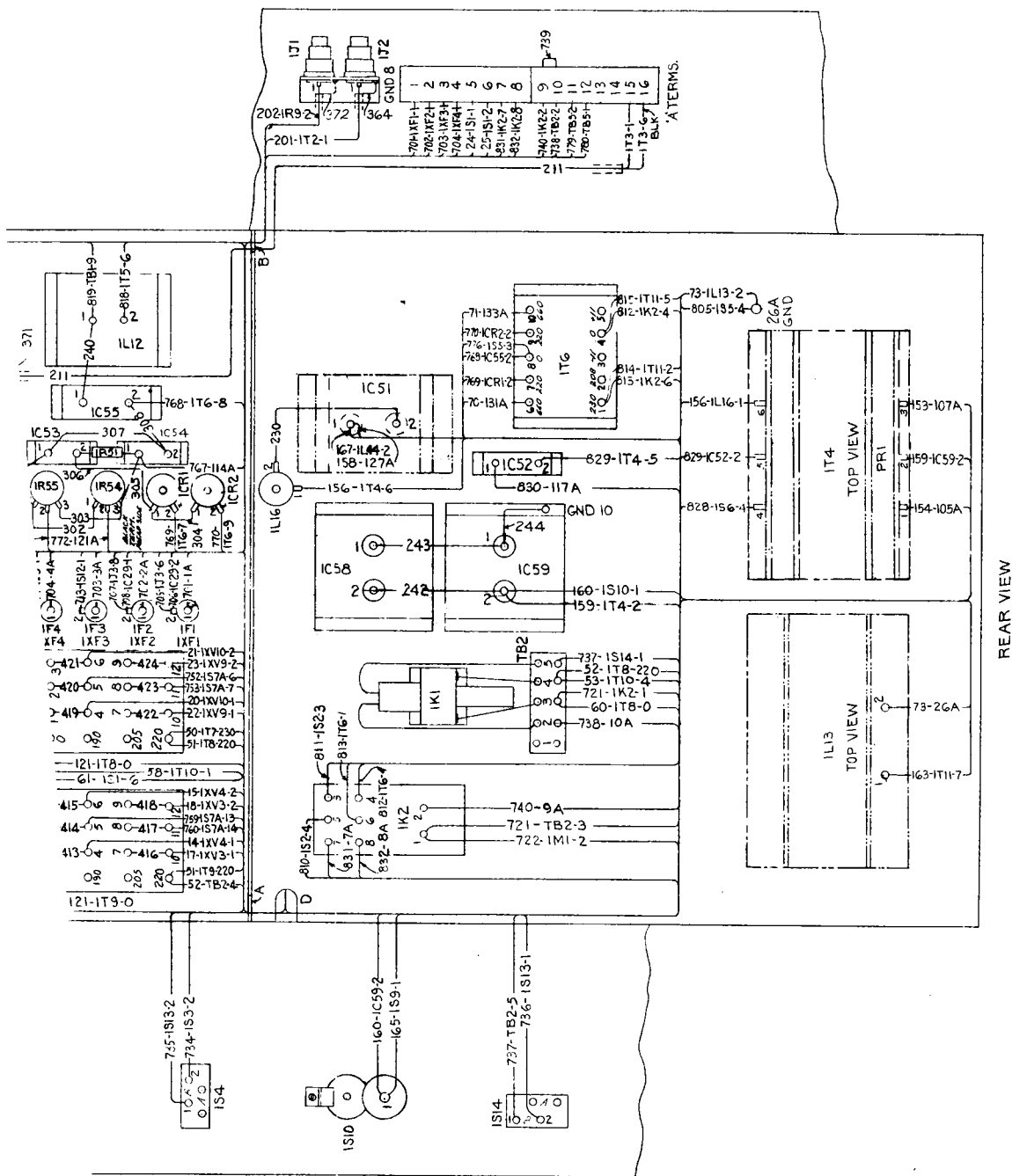

Figure 15. Connection Diagram, Transmitter Rear (318834 sub 2)



**RADIO CORPORATION OF AMERICA**  
INDUSTRIAL ELECTRONIC PRODUCTS, CAMDEN, N. J.

7-21

2

